

## Whirligig – Heavy Duty

**Universal Shaft Sensor Mount for the Most Difficult and Demanding Environments**



*Sensor Installation Made Easy!*

### APPLICATION

The Whirligig Heavy Duty makes shaft speed monitoring much simpler, easier and more reliable. Its all stainless steel heavy duty construction with sealed twin stainless steel bearings make it ideally suited to corrosive and highly demanding environmental conditions. Specify the type of sensor to be installed inside the unit (M100, M300, P100, or P300) and the number of targets/pulses required. Used on conveyors, elevators and other rotating shafts to monitor shaft speed for continuous, low speed or high speed conditions. Machine vibration or movement does not affect the performance of the sensor as the whole assembly moves with the shaft.

### FEATURES

- ▶ Heavy Duty – All Machined Stainless Steel Construction
- ▶ Easy Installation – Only requires M16 Tapped Hole in the Machines Shaft
- ▶ Universal System – Accepts 12mm/18mm/30mm Cylindrical Sensors of Any Length
- ▶ Right or Left Handed Threading Available
- ▶ Safe – Fully Enclosed Targets
- ▶ Available in 1, 2, 4, or 8 Targets/Pulses

### PART NUMBERS/ACCESSORIES

- ▶ WG2-4B-4      Heavy Duty Whirligig
- ▶ M1001V10A      M100 Stopswitch
- ▶ M3001V10AI      M300 Slipswitch (2-Wire)
- ▶ M3005V10AI      M300 Slipswitch (5-Wire)
- ▶ P1001V10A      P100 Proxswitch (2-Wire)
- ▶ P1002V10A      P100 Proxswitch (2-Wire)
- ▶ P1001V34A      P100 Proxswitch (5-Wire)
- ▶ P3002V10A      P300 Proxswitch
- ▶ P3002V10AI      P300 Proxswitch
- ▶ SR2 Series      Speed Relay

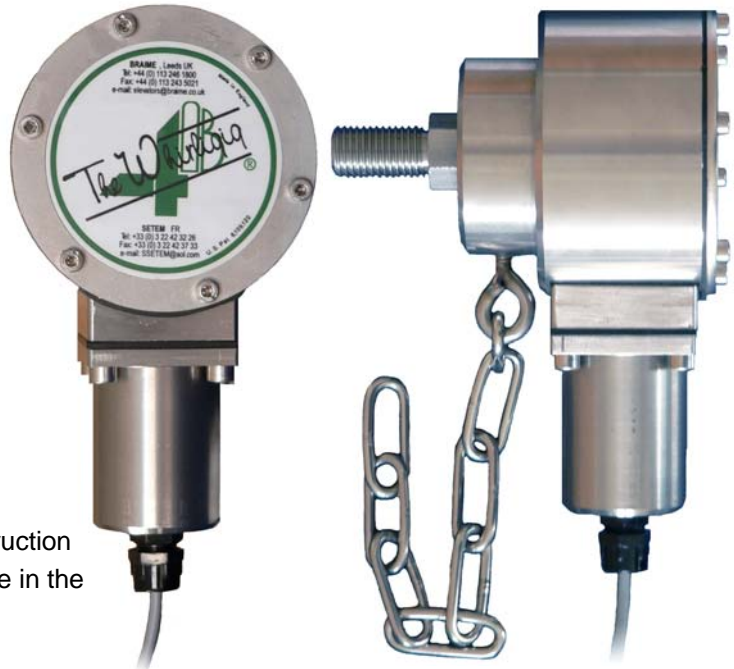

**NEW  
PRODUCT**



Please refer to instruction manual for correct installation.  
Information subject to change or correction. July 2007.

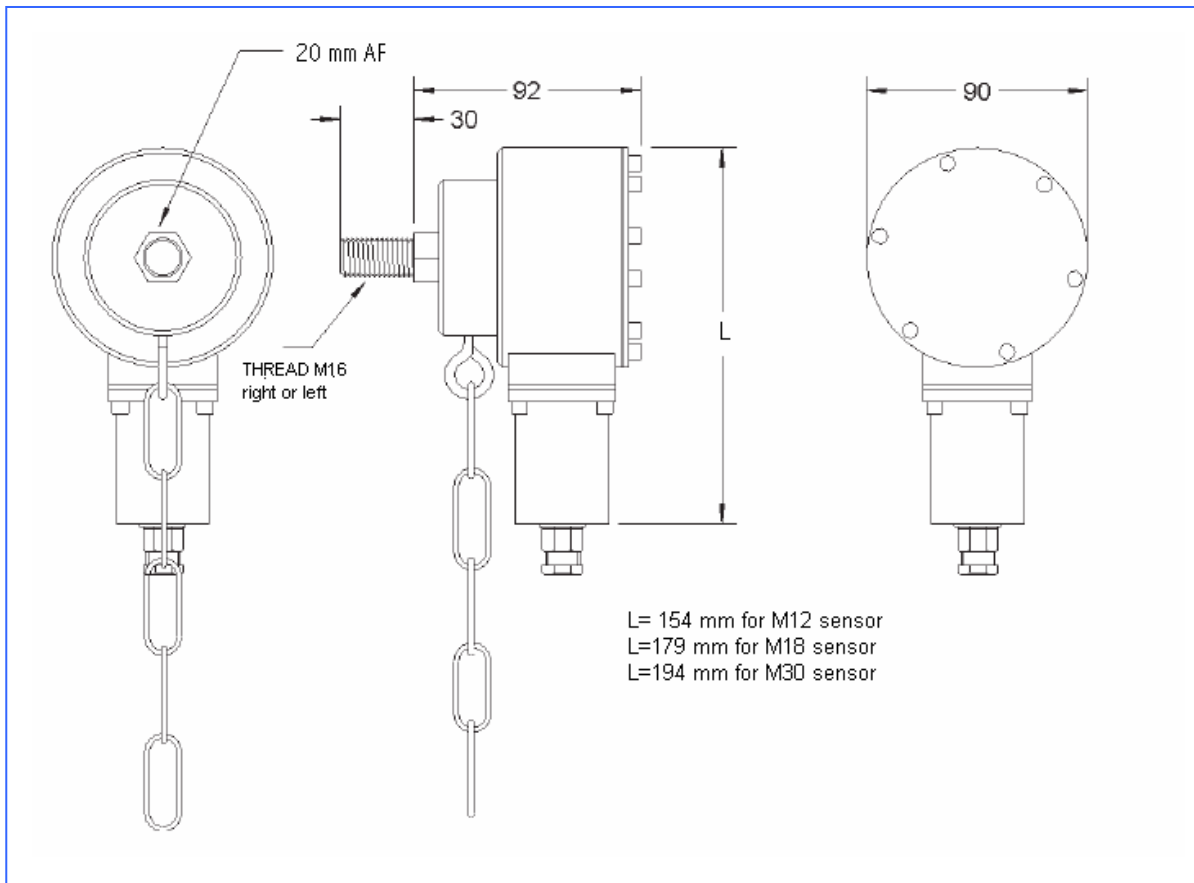

## TECHNICAL SPECIFICATIONS

### Heavy Duty Whirligig – Universal Shaft Sensor Mount

<b>Shaft Material:</b>	Stainless Steel
<b>Body Material:</b>	304 Stainless Steel
<b>Bearing:</b>	Sealed Twin Stainless Steel
<b>Thread Size:</b>	M16 x 2 mm (5/8" UNC Also Available) Specify Right or Left Hand Thread
<b>Temperature:</b>	-9°F to 122°F (-13°C to 50°C)
<b>Maximum Speed:</b>	3000 RPM
<b>Pulses/Targets:</b>	4 (Standard) 1, 2, or 8 Available



Speed Relay (Optional)

Please refer to instruction manual for correct installation.  
Information subject to change or correction. July 2007.