



X400 MANUAL

**Model
X4004V4C & X4004V46C**



**Important: This document should be read carefully before commencing
installation**

Rev. 2.00 – April 2007

CONTENTS

INTRODUCTION

1 SPECIFICATIONS

- 1.1 CONTROL UNIT
- 1.2 ALARM INPUTS

2 INSTALLATION INSTRUCTIONS

- 2.1 CONTROL UNIT
- 2.2 ALARM SENSORS

3 ELECTRICAL WIRING

4 OPERATING INSTRUCTIONS

- 4.1 THE TEST FUNCTION
- 4.2 NORMAL OPERATION
- 4.3 ALARM WARNING
- 4.4 ALARM MUTE
- 4.5 ALARM STOP (SHUT DOWN)
- 4.6 RESTARTING

5 FAULT FINDING

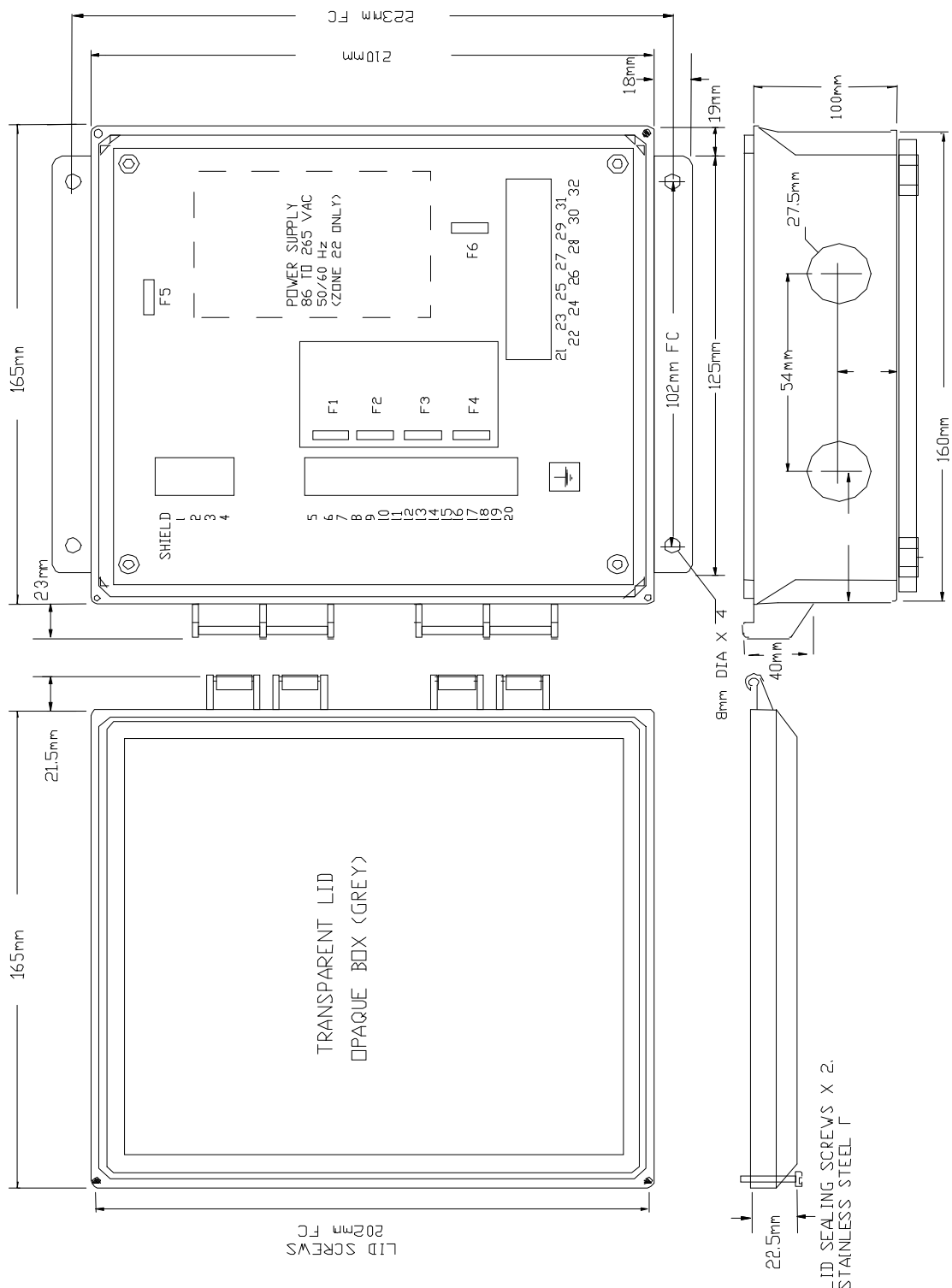

DRAWINGS

- A BLOCK DIAGRAM
- B DC SUPPLY AND RELAY WIRING
- C AC SUPPLY AND RELAY WIRING
- D TYPICAL SENSOR CONNECTION DETAILS





Approvals

Certification Markings: Model X4004V4C (24 VDC)

 Class II, Division 1, Groups E, F & G (Canada)
c _{US} Class II, Division 2, Groups F & G (USA)

Certification Markings: Model X4004V46C (100-240 VAC)

 Class II, Division 2, Groups F & G (Canada)
c _{US} Class II, Division 2, Groups F & G (USA)

Power dissipation in Watts

CSA Division 1 : 12 Watts

CSA Division 2 : 12 Watts

To Open the Lid:

1. Disconnect power (isolate ALL circuits)
2. Untighten the lid securing screws
3. Carefully open the lid ensuring that the gasket is not damaged and remains in place

To Close the Lid:

1. Check that the gasket is correctly fitted into the box groove and is undamaged.
2. Tighten the lid screws.
3. Check that the lid and box are correctly mated.

Special conditions for safe use:

WARNING: Static Hazard - Clean only with a damp cloth.

X400 ELITE ALARM MONITOR

INTRODUCTION

The X400 ELITE is a microprocessor controlled unit which is able to accept signals from different sources in 8 zones and is able to cause alarm and shutdown of the machine when alarm conditions are detected. The control unit is housed in a self contained wall-mounting enclosure. The X4004V4C ELITE is designed to work in a Zone 21/22 environment and will operate from 24v DC. The X4004V46C ELITE is designed to work in a Zone 22 environment and will operate from 100-240 VAC.

1. SPECIFICATIONS

1.1 The Control Unit

A plastic enclosure houses the electronics and terminal connectors. The unit contains a printed circuit board to accommodate power supply circuitry, output relays, microprocessor and terminals. A short ribbon cable is connected to the lid of the enclosure where the indicator lamps are mounted. A 'touch button' is mounted on the lid to allow the unit to be tested during operation. A second 'touch button' allows the alarm signal to be muted.

Electrical Supply X4004V4C	-	24VDC +/- 10%
X4004V46C	-	100-240 VAC +/- 10%
Power Consumption	-	12 WATTS
Alarm Relay Contacts	-	1 Pole normally open 8A@ 250VAC
Stop Relay Contacts	-	1 Pole normally open 8A@ 250VAC
Alarm Inputs	-	10 – 30 VDC+/-10%
Remote Alarm Mute	-	24VDC or 100-240 VAC
Terminals	-	Power 4mm ² 14 AWG max
	-	Signals 2.5mm ² 16 AWG max Plug In
Protection	-	NEMA12, IP66
Height	-	9.7", 246mm
Width	-	7.4", 188mm
Depth	-	4", 102mm
Fixing Centres	-	8.75" high x 4" wide, 222mm x 102mm
Cable Entry	-	2 Holes 11/8" DIA, 28mm, 3/4" CONDUIT
Weight	-	3lbs, 1.3Kg

Status Indicator Lamps	-	Viewed through front panel
	-	POWER
	-	1 (Input 1)
	-	2 (Input 2)
	-	3 (Input 3)
	-	4 (Input 4)
	-	5 (Input 5)
	-	6 (Input 6)
	-	7 (Input 7)
	-	8 (Input 8)
	-	ALARM
Touch Buttons	-	MUTE
	-	TEST

1.2 Alarm Inputs

These are eight separate Alarm Inputs on the control unit arranged in four pairs. Each input needs a DC voltage in the specified range to be in the ON state.

The inputs are designed to be OFF when there is no alarm condition. Applying the input voltage, ie turning it ON is considered to be an alarm condition.

The inputs are designed to function between 10 and 30 VDC. Terminal 17 can provide a 24VDC supply for use as a voltage source for any remote sensors used. The 24 VDC supply has a limit applied to it and will cause a fuse to blow (F5) if the current is exceeded. The current limit for model X4004V4C is 200mA (Zone 21) and the current limit for model X4004V46C is 1Amp (Zone 22). Usually, the same voltage source is used for all alarm inputs but it is permitted to use different DC voltages (10 – 30 VDC) as all inputs are opto-isolated. As the inputs are arranged in pairs with one common terminal for each pair, it is necessary to use the same voltage source for each pair of inputs.

2 INSTALLATION INSTRUCTIONS

Warning:

Always lock-out and tag-out the machine prior to installation and set-up.

Wiring: All Wiring Must Be In Accordance With Local and National Electrical Codes and Should Be Undertaken By an Experienced and Professional, Qualified Electrician.

2.1 The Control Unit

The Control Unit box should be installed in a suitable control or starter switch room and mounted at an eye level position so that the warning lights can be readily seen. The box should have sufficient space to open the lid for wiring and adjustment. An audible alarm, sounder or visual indicator lamp can be installed in or outside of the control room.



The Control Unit is susceptible to static voltage. Connection of a clean ground to terminal 31 is essential for optimum performance. Prior to this connection, static handling precautions should be taken.

Enclosure Installation:

- a. The IP66 rating of the enclosure must be maintained when used Zone 21 dust environment. You must use the correct cable, glands and sealing arrangement and in accordance with the national installation codes.
- b. Where other certified components are used as part of the assembly or installation procedure, the user must take in to account any limitations which might be listed on the relevant certificates.
- c. The box is supplied with 2 x 27.5mm (1¹/₈"") pre drilled holes in the bottom face. All unused entry apertures must be sealed using certified stopping. The end user must install certified stopping plugs and cable glands in strict accordance with the manufacturer's instructions. **Further holes must not be added to the enclosure as this will invalidate any warranty and the product certification.**
- d. All wiring must be carried out in accordance with relevant codes of practice and / or instructions.
- e. The voltage and current and maximum power dissipation shown on the box label must not be exceeded.
- f. All leads must be insulated for the appropriate voltage.
- g. A parallel shaft screwdriver of the correct size should always be used when tightening terminals.

2.2 Alarm Sensors

Many types of sensors can be used with the X4004 ELITE control unit. If the sensor provides a voltage signal within the specified range, it can be connected directly to the input. If the sensor uses a relay contact, it must be connected to a voltage source as shown on the wiring drawings.

3 ELECTRICAL WIRING

Refer to Drawings A to D

Mount a conduit junction box within 6ft (2 metres) of each sensor – generally one junction box can be used for a pair of sensors. Connect the sensor cable to the junction box using sealing glands and protect the cable from damage. Connect the junction box back to the control unit. We strongly recommend the use of shielded wires when wiring the sensors to the control unit. When terminating conduits at the control unit, ensure ground continuity by using a suitable bushing such as Allen Bradley 1490-N19.

When installing the equipment in an area which is likely to be hazardous from Ignitable Dusts, use liquid tight conduit and fittings and follow all local codes.

4 OPERATING INSTRUCTIONS

4.1 The TEST function

4.1.1 Normal Test

The X4004 ELITE is equipped with a self test function, initiated by the TEST button on the lid of the control unit. When the Test button is touched, the Alarm lamp flashes and then the following automatic test is initiated as the Test button is released.

1. All lamps illuminate – the ALARM lamp continues to flash
2. After 5 seconds all lamps return to their normal conditions

This test can be performed when the machine is running or stopped and tests the correct function of the microprocessor and of all lamps.

4.1.2 Extended Test

If the Normal Test is initiated as in 4.1.1 and if the Test button is touched again, while the ALARM lamp is flashing, the extended test operates as follows:

1. All lamps illuminate – the ALARM lamp continues to flash
2. The Test button is touched a second time
3. The ALARM and INPUT 8 lamps flash for a further 5 seconds (8 seconds total time)
4. The ALARM RELAY and STOP RELAY are inverted. INPUT 7 lamp flashes
5. After 3 seconds all lamps and relays return to their normal conditions

If this test is performed when the machine is not running, the Alarm will sound but the STOP RELAY will have no effect on the machine. If this test is performed when the machine is running, the Alarm will sound and the STOP RELAY will stop the machine! This test should be performed on a regular basis to check the safety of the installation.

4.2 Normal Operation

If all Inputs are OFF, all eight INPUT indicator lamps will be off. The ALARM indicator lamp and ALARM relay will be off. The STOP relay will be energised.

4.3 Alarm

If an INPUT is ON, the associated INPUT indicator lamp and ALARM lamp will illuminate. After approx 2 seconds, the ALARM relay will energise. If the INPUT then changes to OFF, the Input indicator lamp will also go off. If no other alarms are present then the ALARM lamp and ALARM relay will also turn off.

If more than one Input is ON all associated Input indicator lamps will illuminate. Only when all Inputs are acknowledged (MUTED) will the ALARM relay de-energise. The alarm indicators will remain until the alarm condition is removed.

4.4 Alarm Mute

If the ALARM lamp and ALARM relay are energised because of an Input, the ALARM may be muted (turned off) by the following methods. When the Mute button is touched, the ALARM lamp flashes, the ALARM relay de-energises and all Input indicator lamps which were illuminated will flash. Alternatively, if a voltage is applied to the MUTE input terminals, the same MUTE action will occur. If the Inputs return to OFF the alarm indicator will also turn to off.

If, during a MUTE condition, a further Input changes to ON, the associated Input indicator lamp will illuminate, the ALARM lamp and relay will energise leaving the original muted Input indicator lamps flashing. A further MUTE operation would flash all associated Input indicator lamps.

4.5 Alarm Stop (Shut Down)

If an Input ON condition is detected, and if the ALARM indicator lamp is on (whether muted or not) for more than 3 minutes, the STOP relay will de-energise. If the ALARM condition is cleared in less than 3 minutes, the STOP relay will not de-energise but the amount of alarm time will be 'remembered'. If the ALARM condition occurs again immediately, the 'shut down timer' will continue from where it last stopped until the 3 minutes is completed. If the ALARM condition does not occur again immediately, the 'shut down timer' will time backwards, reducing the amount of time 'remembered' until the timer reaches zero. Consequently, if the alarm condition is intermittent, but no single interval of alarm exceeds 3 minutes, the persistence of alarms can eventually result in a STOP condition.

4.6 Restarting

If the machine has stopped because of an Input condition as in 4.5 the lamps described above will remain flashing indefinitely. As soon as the Inputs return to OFF, the flashing lamps will be cancelled, and the ALARM and STOP relays will be reset.

Liability and Indemnity:

- 1) **In respect of installation or applications of the goods as parts or components of other goods or machinery the buyer shall be solely responsible for the compliance and the installation with safety regulations issued by competent authorities and in force at the place of operation and/or for its compliance with any terms of insurance notified by the Buyer's insurance for personal injury or damage to property or loss of profit though fire, explosion, gas, or otherwise.**
- 2) **Neither the company nor its suppliers shall in any circumstances whatsoever be liable for any loss or damage suffered by the Buyer or by any third party howsoever caused involving any person, property, or interest, suffered by the Buyer or any third party directly or indirectly in connection with the use, functioning or state of the goods, unless the same shall arise out of the Company's negligence.**
- 3) **The buyer shall indemnify the Company against all actions, claims, or demands by third parties, whether in tort or otherwise, howsoever arising, directly or indirectly, in connection with the use, functioning or state of the goods or in connection with the performance of service.**

Limitation of Liability

Without prejudice to the foregoing, the Company shall in no circumstances be liable:

- 1) **For any incidental or consequential loss or damage suffer by the buyer, including without limitation, delay, detention, loss of production, loss of profit, or liability to third parties except liability for personal injury or death arising out of negligence by the Company.**
- 2) **For any loss or damage covered by the insurance or which would ordinarily be covered by the insurance.**

Warranty

The equipment is covered by 12 months warranty from the date of dispatch. Any faults arising due to faulty materials or workmanship in the original equipment within the warranty period will be corrected free of charge providing the equipment is returned to us freight paid.

CHECKLIST
For problems after initial start-up

1. Is there excessive interference on the electrical power supply? Power conditioners and surge (spike) suppressor may have to be fitted.
2. Has the wiring for the Sensors been routed away from power cables? See paragraph 3.
3. Is the X4004 Elite circuit properly grounded?
4. Is the Micro-processor control unit overheating, if so mount in temperature-controlled environment of maximum temperature 104°F (40°C).
5. Check that high powered 'Walkie Talkie' radios are not operated immediately near the X4004 Elite control unit or Sensors as this will affect the performance.

5. FAULT FINDING CHART

SYMPTOM	CAUSE	REMEDIAL ACTION
Input LED on Control Unit does not illuminate	Sensor not operating Wiring Fault Sensor connected to wrong terminals	Replace Sensor Check wiring
Input LED on Control Unit on continuously	Wiring fault Sensor fault	Check wiring Check sensor
Wrong input LED on unit illuminates	Sensor connected to wrong input	See drawing F
Alarm LED on	Input is ON	Check Sensors
Relay off	Stop condition occurred	Alarm condition for more than 3 minutes
Machine fails to start	Wiring fault	Check wiring



For further information relating to this and other products go to www.go4b.com

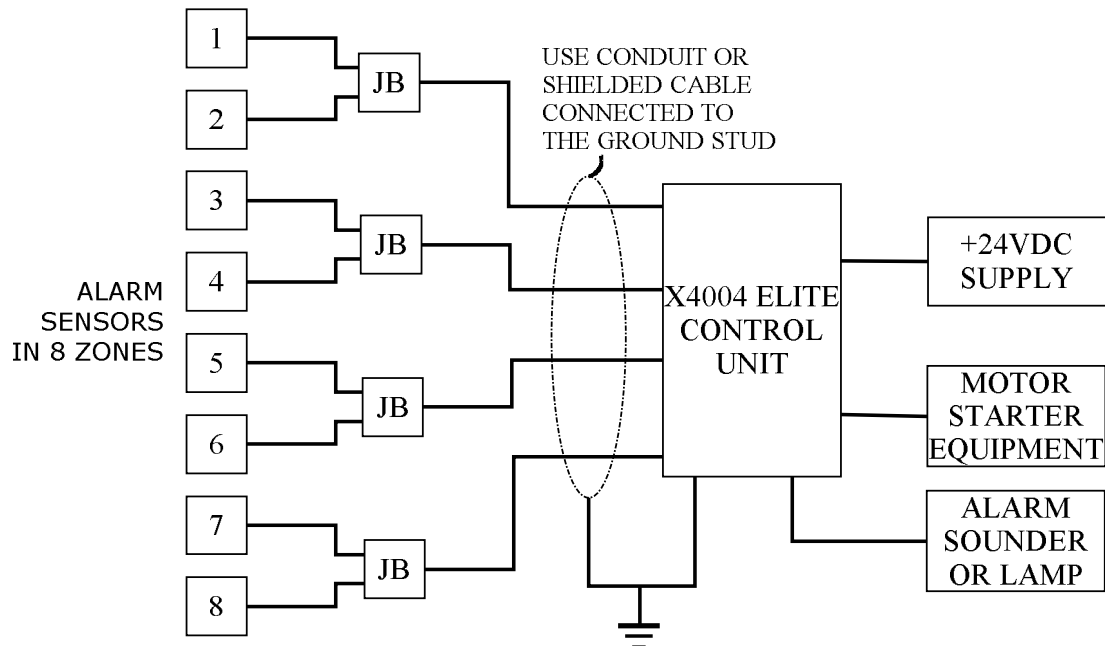
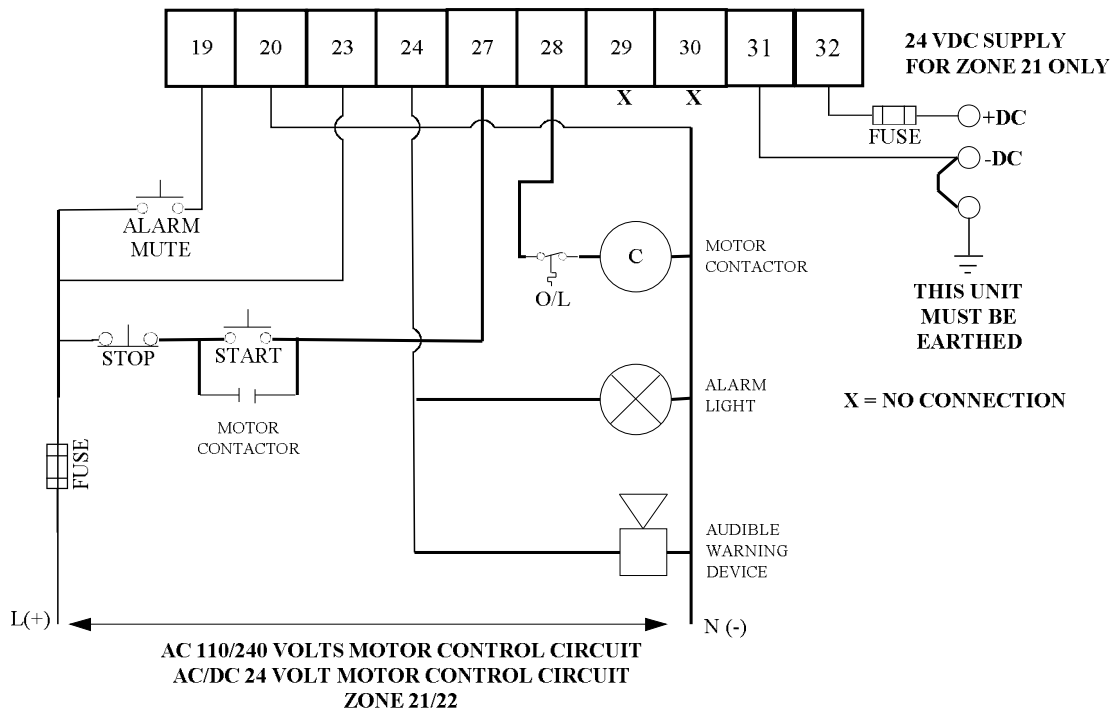
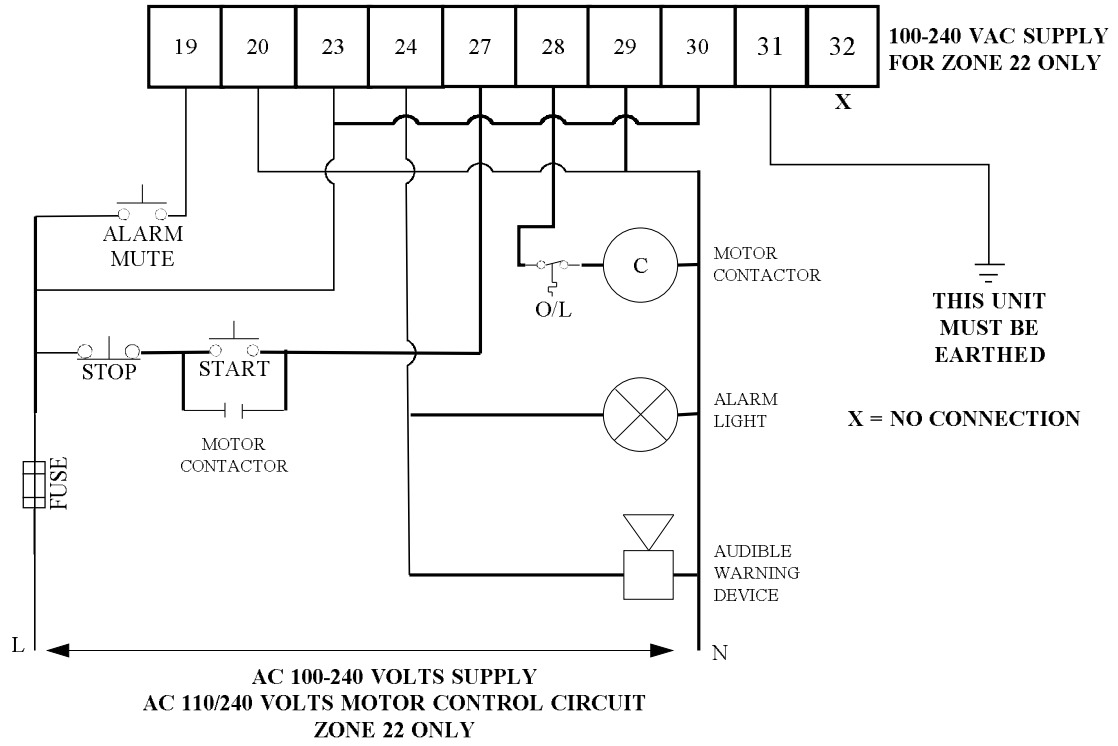

DIAGRAM A - BLOCK DIAGRAM

DRAWING B - DC SUPPLY CONNECTIONS WITH AC/DC MOTOR CIRCUIT.



**DRAWING C - AC SUPPLY CONNECTIONS
WITH AC MOTOR CIRCUIT.**



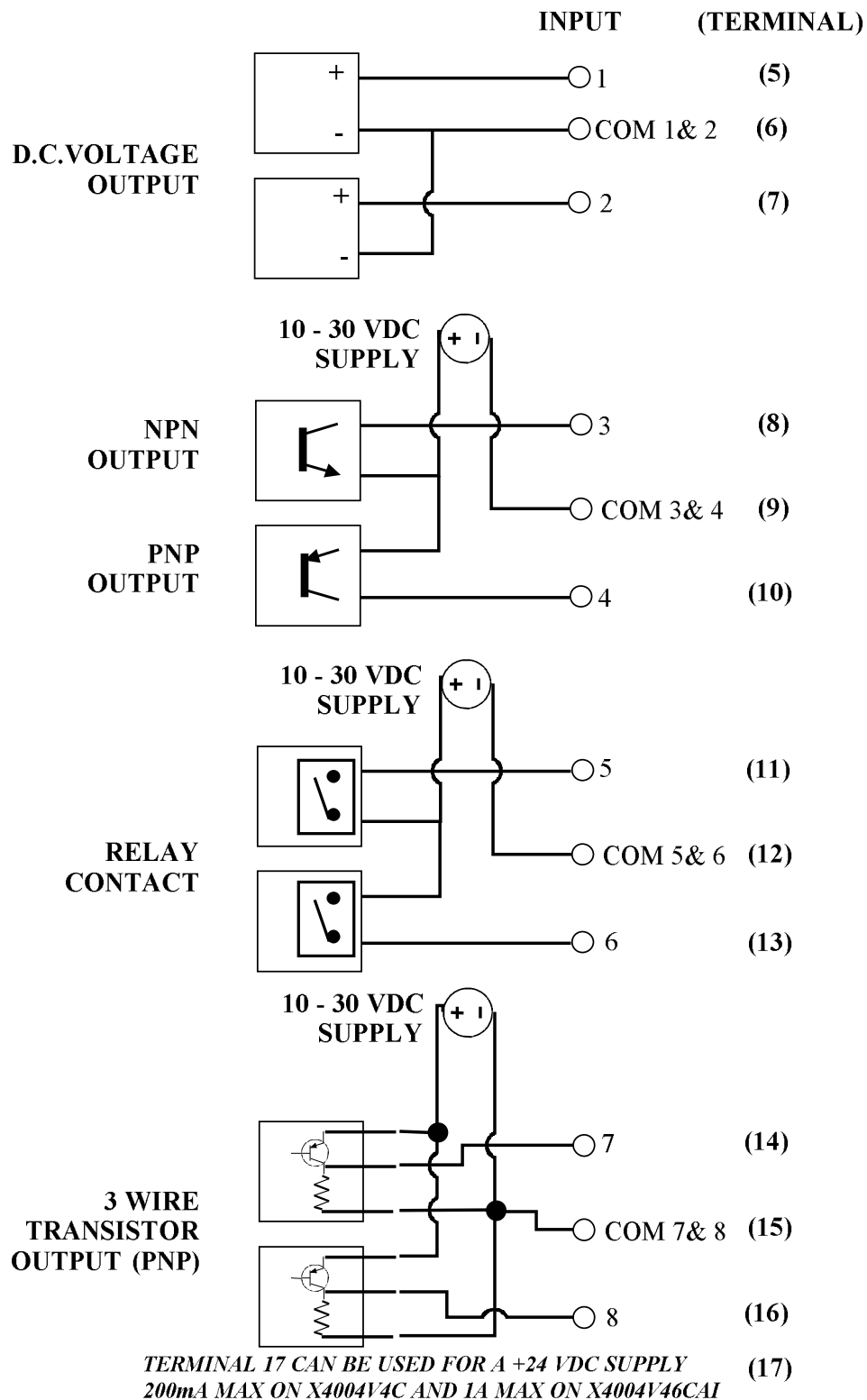

**DIAGRAM D - TYPICAL ALARM SENSOR
CONNECTION (DC ONLY)**