

# TILT SWITCH

## Type: TST1VOA

Manual No: M2455

642-032(A)

### Introduction

The tiltswitch is a simple means of level sensing for grain and similar materials.

The end 'pod' contains a switch which is normally closed when hanging in free air and changes to open when it is tilted.

The main housing allows for easy fitting of the unit to a vessel, and contains the power supply, output circuit and a timer to eliminate the effect of vibration in the tiltswitch 'pod'.

### Installation

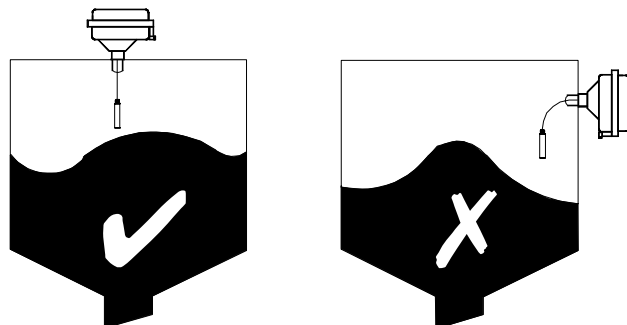

### Dimensions

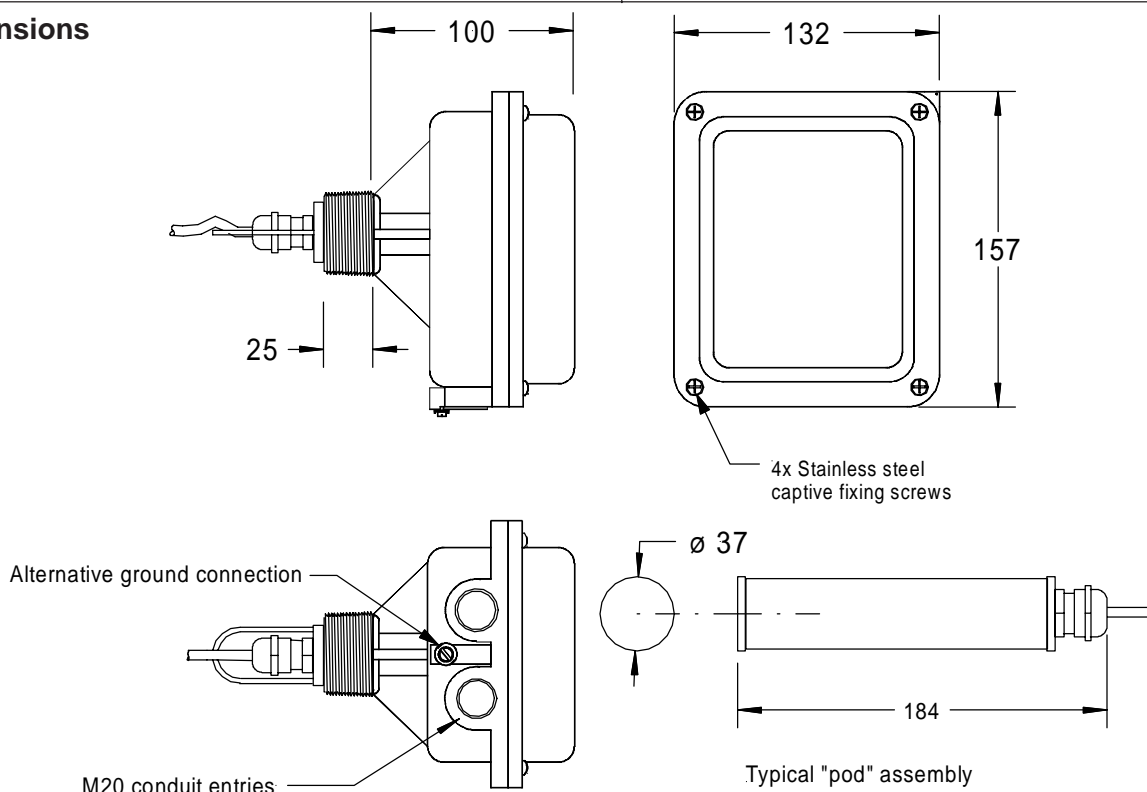

### Specification

Supply: 24V dc, 110/230V ac. 50/60Hz.  
Supply Rating: 1.8VA.  
Output: S.P.C.O relay 3A 240V ac max. Non inductive.  
Indication: LED indication of Power On and Output On.  
Mounting: 1 1/4" NPT male thread.  
Enclosure Material: Glass filled nylon.  
Ingress Protection: IP65.  
Cable Entries: 2 off M20 x 1.5mm  
Storage Temp.: -20°C to +65°C  
Operating Temp.: -20°C to +50°C.  
Operating Tilt angle: Approximately 15°  
Operating Speed: Set by timer. (See below).  
Operating Timer: 0-20 sec. (adjustable).  
Approval: A3-300232A Baseefa03ATEX0122  
(Ex) II 1D T100°C Tamb -20°C to +50°C IP65

### Connections

Output mode selector switch. Factory preset at High.

#### IMPORTANT NOTE:

The Tiltswitch is supplied with a fuse fitted in the AC fuseholder, fit into the DC position for 24V dc operation.  
The fuse rating for this unit is 50mA anti-surge, IEC.

**NO OTHER RATING MAY BE USED**

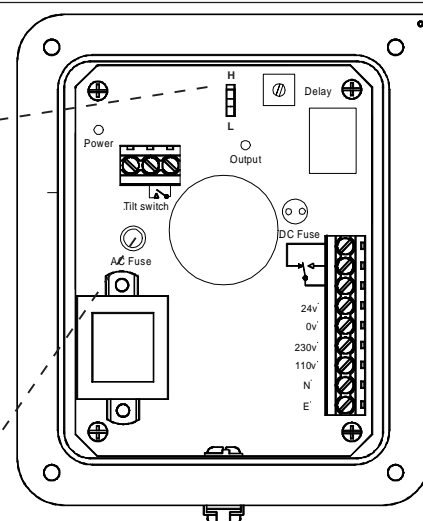

**BRAIME ELEVATOR COMPONENTS LTD.**  
England. LS10 1JZ  
Telephone: (0113)2461800  
Fax: (0113)2435021  
Web: www.braime.com  
e-mail: elevators@braime.co.uk



**SETEM**  
2 Route de Corbie  
80800 Lamotte Warfusée, France  
Telephone: 03 22 42 32 26  
Fax: 03 22 42 37 33  
e-mail: SSETEM@aol.com  
Web: www.braime.com/setem