

T500 Elite

MANUAL

(Software Version 2.3.0)

CONTENTS

INTRODUCTION

1 SPECIFICATIONS

- 1.1 CONTROL UNIT
- 1.2 BEARING TEMPERATURE SENSORS
- 1.3 TEMPERATURE NODE TN4e.
- 1.4 R500 RELAY OPTION
- 1.5 HOTBUS 2

2 INSTALLATION INSTRUCTIONS

- 2.1 CONTROL UNIT
- 2.2 BEARING TEMPERATURE SENSORS

3 ELECTRICAL WIRING

4 OPERATING INSTRUCTIONS

- 4.1 T500 ELITE SET UP
- 4.2 NORMAL OPERATION
- 4.3 SENSOR ALARM DETECTION AND DISPLAY
- 4.4 ALARM LOG
- 4.5 WARNING RELAY CANCEL (ACKNOWLEDGE)
- 4.6 ALARM CONDITION SETUP
- 4.7 T500 MENU SELECTION
- 4.8 SENSOR NAME EDITING
- 4.9 DOWNLOADING

CHECKLIST

5 CONTACT INFORMATION

DRAWINGS

- A CONNECTING THE T500 ELITE TO AN AC SUPPLY
- B CONNECTING THE T500 ELITE TO A DC SUPPLY
- C FITTING OF TEMPERATURE SENSOR TO BEARING
- D GENERAL INTERCONNECTION DIAGRAM
- E R500 RELAY INTERFACE CONNECTION DETAIL
- F CONNECTING THE R500 TO AN AC SUPPLY
- G CONNECTING THE R500 TO A DC SUPPLY
- H T500/R500 HOTBUS 2 CONNECTIONS
- J TN4e HOTBUS 2 AND SENSOR CONNECTIONS

T500 ELITE SENSOR MONITOR

INTRODUCTION

The T500 ELITE is a microprocessor-controlled unit, which is able to accept signals from temperature sensors or voltage free thermostat and relay contacts in groups of 1 to 4, and is able to cause alarm and shutdown of a machine when alarm conditions are detected. The control unit is housed in a self-contained wall-mounting enclosure. The temperature sensors are separate items for mounting on bearings and the contact sensing may be any voltage free contact device having either **Normally Open** or **Normally Closed** contact state. The T500 ELITE will operate from 115v to 230v AC or from 12v to 24v DC.

1. SPECIFICATIONS

1.1 The Control Unit

A plastic enclosure houses the electronics and terminal connectors. The unit contains a printed circuit board to accommodate power supply circuitry, alarm relay, microprocessor and terminals. A short ribbon cable is connected to the lid of the enclosure where the display, keyboard and led indicators are mounted.

Electrical Supply	-	115 / 230 Volts AC 50 / 60 Hz
	-	12 / 24 Volts DC
Power Consumption	-	10VA/10 WATTS
Alarm Relay Contacts	-	1 Pole normally open 8A@ 250VAC
Sensor Inputs	-	Via an RS485, 2 wire communications network
Sensor Supply	-	12V DC (150 ma available)
Terminals	-	Power 4mm ² 14 AWG max
	-	Signals 2.5mm ² 16 AWG max Plug In
Protection	-	NEMA12,IP55,Class II DIVI,E,F,G
Height	-	9.7", 246mm
Width	-	7.4", 188mm
Depth	-	4", 102mm
Fixing Centres	-	8.75" high x 4" wide, 222mm x 102mm
Cable Entry	-	2 Holes 11/8" DIA, 28mm, 3/4" CONDUIT
Weight	-	3lbs, 1.3Kg
Maximum number of TN4e	-	64
Maximum connected sensors	-	256 (4 per TN4e)
Maximum alarm relays	-	64 (In groups of 16 by using the optional R5001V345 interface)
Sensing temperature range	-	-23°F to +230°F
Display	-	4 line by 20 characters LCD with backlight.
Keyboard	-	5 programming keys.
Status Indicator Lamps	-	Viewed through front panel
	-	POWER
	-	ALARM

1.2 Bearing Temperature Sensors

1.2.1 Bearing Temperature Sensor, NTC – WDB10V3CA / WDB20V3CA

The temperature Sensor is designed to screw into the bearing housing in a grease nipple hole or other tapped hole and will detect excessive temperature of the bearing housing. The body of the sensor contains a negative temperature coefficient (NTC) thermistor, which has a variable temperature characteristic. Four WDBX0V3CA sensors can be connected to a TN4e temperature node. A two cores plus drain cable is permanently attached to the sensor body. A grease nipple is provided in the body of the sensor to allow greasing of the bearing in the normal manner.

SENSING TEMPERATURE	-	-23°F to 230°F (-31°C to +110°C)
ACCURACY	-	±1.8°F (1°C)
SENSING VOLTAGE	-	5V DC Approx
NORMAL OPERATING CURRENT	-	1 ma
FIXING THREAD	-	1/8" NPT
CABLE	-	2 Core + drain 0.75mm ² 9ft (3Mtr.) long
PROTECTION	-	Ex II 1 D T125°C BAS01 ATEX 1191X. CSA Class II Division I GROUPS E, F AND G

1.2.2 Bearing Temperature Sensor, PTC – WDB24V3CA (typical example)

The temperature Sensor is designed to screw into the bearing housing in a grease nipple hole or other tapped hole and will detect excessive temperature of the bearing housing. The body of the sensor contains a positive temperature coefficient (PTC) thermistor, which has a fixed temperature characteristic. Four WDB24V3CA sensors can be connected to a TN4e temperature node. A two cores plus drain cable is permanently attached to the sensor body. A grease nipple is provided in the body of the sensor to allow greasing of the bearing in the normal manner.

TRIP TEMPERATURE	-	176°F (80°C) [this example only]
SENSING VOLTAGE	-	5V DC Approx
NORMAL OPERATING CURRENT	-	1 ma
FIXING THREAD	-	1/8" NPT
CABLE	-	2 Core + drain 0.75mm ² 9ft (3Mtr.) long
PROTECTION	-	Ex II 1 D T125°C BAS01 ATEX 1191X. CSA Class II Division I GROUPS E, F AND G

See page 13 for a complete list of PTC type numbers and temperatures.

1.3 Temperature Node TN4e.

The TN4e is supplied either in an ABS housing complete with cable glands for use in Europe or in a Crouse-Hinds type CU enclosure. The TN4e is equipped with a microprocessor which will provide up to four scaled and linear temperature readings in the range -23°F to +230°F ±2°F. The microprocessor design ensures a consistently reliable performance. The T500 elite communicates with the TN4e using an industrial standard RS485 communications system. The T500 also provides power for each of the 64 TN4e through the communications cable. When operating with 64 TN4e connected the time taken to update all of the 256 temperatures is approximately 8 seconds. An industrial standard Belden or equivalent two twisted pair communications cable is used to connect the T500 elite to the TN4e. This communications bus is referred to as HOTBUS 2. The HOTBUS 2 uses one pair of cables to carry the communications signals and another pair to carry the power supply. The cable includes an overall screen to provide signal protection.

SENSING TEMPERATURE	-	-23°F to +230°F
ACCURACY	-	±2°F
SUPPLY VOLTAGE	-	12V/24V DC ±10%
MAX. CURRENT	-	5ma (Peak, Including LED)
PROTECTION	-	IP65
CABLE TYPE	-	BELDEN 8132 (UL2919) or equivalent

1.4 Optional Relay Interface.

The optional R50016V345 relay interface unit is equipped with 16 alarm relays. Each relay provides a single pole changeover contact rated 250V AC at 5Amp. The T500 can be programmed to operate with up to 64 alarm relays with any number of sensors programmed to operate any alarm relay. When a sensor exceeds its programmed alarm tolerance, the relay associated with that sensor will operate.

R50016V345 Electrical specification

Electrical Supply	-	115 / 230 Volts AC ±10% @ 50 / 60 Hz
	-	12 / 24 Volts DC ±10%
Power Consumption	-	10VA/10 WATTS
Alarm Relay Contacts	-	1 Pole change over 5A@ 250VAC x 16
Terminals	-	Power 4mm ² 14 AWG max
	-	Relay 2.5mm ² 16 AWG max PLUG IN
Protection	-	NEMA12,IP55,Class II DIVI,E,F,G
Height	-	9.7", 246mm
Width	-	7.4", 188mm
Depth	-	4", 102mm
Fixing Centres	-	8.75" high x 4" wide, 222mm x 102mm
Cable Entry	-	2 Holes 1 1/8" DIA, 28mm, 3/4" CONDUIT
Weight	-	3lbs, 1.3Kg
Status Indicator Lamps	-	POWER
Unit Address range	-	0 – 7 (Factory Default = 0)

The T500 Elite software Version 2.x.x has been designed to support 4 R50016V345 relay interface units. Together they provide a total of 64 alarm relays. Each relay interface is fitted with a unit address selector switch. This switch allow up to 8 unit addresses although

only the first 4 are currently used. Address '0' provides relays in the range of 1 to 16 and address '1' provides relays in the range 17 – 32, address '2' provides relays in the range 33 – 48 and address '3' provides relays in the range 49 - 64. The address must be set BEFORE power is applied. The relay interface units are shipped from the factory set to address '0'. If you intend to use 2, 3 or 4 relay units you must set each of the R500 interfaces to address 1, 2, or 3 accordingly. Additional relay interface units may be connected to the HOTBUS communications network using the same unit address. This will duplicate exactly the functions of the first unit. This can be useful when local and remote alarm indication may be needed.

1.5 HOTBUS 2

HOTBUS 2 is the term used to refer to the communications system used with the T500 elite and the sensor network. This network is an active communications system and as such is not restricted to monitoring temperatures. Other HOTBUS 2 sensors will become available in the future and can be mixed freely on the HOTBUS 2 system.

2 INSTALLATION INSTRUCTIONS

2.1 The Control Unit

The Control Unit box should be installed in a suitable control or starter switch room and mounted at an eye level position so that the warning lights and display can be readily seen. The box should have sufficient space to open the lid for wiring. An audible alarm, hooter or visual indicator lamp can be installed in or outside of the control room.



The Control Unit is susceptible to static voltage. Connection of a clean ground to terminal 29 is essential for optimum performance. Prior to this connection, static handling precautions should be taken.

2.2 Bearing Temperature Sensors (Grease through type)

The temperature sensors are screwed into the grease holes of the bearings for the elevator leg head pulley, boot pulley and jockey pulley, where fitted or the bearings for conveyor rollers. Each sensor has a greasing by-pass and is installed in the bearing as Drawing 'C'.

3 ELECTRICAL WIRING

Refer to Drawings A & B

Mount the TN4e housing within 3 meters of the sensors. Connect the sensor cables to the TN4e box SENSOR 1, SENSOR 2, SENSOR 3 and SENSOR 4 inputs using the provided sealing glands and protect the cable from damage. If flexible conduit is to be used ensure the correct glands are also used. Connect the communications/power cable to the TN4e box via the remaining 9-way plug connector. The cable is intended to be daisy chain connected as described in Drawing 'D'.

Any Sensor inputs, which are unused, may be left unconnected but attention must be paid to ensure that the procedures set out on page 19, items 10 to 12 are carried out.

When installing the equipment in an area which is likely to be hazardous from Ignitable Dusts, use liquid tight conduit and fittings and follow all local codes.

4 OPERATING INSTRUCTIONS

The operator keys and their use.

The T500 elite is equipped with 5 programming keys. These keys change their function according to the operation required at the time. When entering a numeric value, the following format has been adopted.

UP (▲) key will increase the selected number.

DOWN (▼) key will decrease the selected number.

LEFT (◀) will move the flashing cursor one digit to the left

RIGHT (▶) will move the flashing cursor one digit to the right

SET will accept the number on the screen and move to the next entry.

If the flashing cursor is placed on a digit using the (◀) or (▶) keys then the number will be increased or decreased by an appropriate amount.

For example:

If the display shows 0000 then pressing (▲) will increase the number by 1

If the display shows 0000 then pressing (▲) will increase the number by 10

If the display shows 0000 then pressing (▲) will increase the number by 100

If the display shows 0000 then pressing (▲) will increase the number by 1000

The (▼) key operates in exactly the same way except that it will decrease the number by the same amount. Each number has a programmed range and will not allow numbers outside of that range. If you press and hold the (▲) or (▼) key for greater than 2 seconds, then the numbers will increase or decrease at a faster rate. Due to a low software priority the key repeat rate will vary, this is normal and should not be a cause for concern. When you are satisfied that the number being displayed is correct, press the SET key to save this number and move on to the next entry.

At other times the keys will have different functions. Please refer to those functions in order to determine the key use.

WARNING: If you are in a menu or edit mode and do not press a key for 1 minute, the edit menu will close and any data entered will be lost.

The TEST function

When the T500 is powered up a greetings message is displayed and it automatically enters a self-test mode. All of the internal functions are examined and if no errors are detected the software continues into normal operation. In the event of failure, please contact the factory.

**	T500 ELITE	**
	© 2003-2004	
	WHEAT ELECTRONICS	
**	VERSION 2.3.0	**

4.1 Initial Setting up

When power is first applied to the T500 the software checks for the existence of set-up information. If this is not present then it is assumed that the T500 is being set-up for the first time. The warning message opposite will be displayed and the alarm LED will flash.

```
WARNING
No Configured
sensors, press SET
to begin
```

The T500 will not continue until the SET button is pressed. At this point the LCD display will change to the T500 setup screen. This option can be accessed at any time once the initial setup has been performed.

```
- NODE SETUP -
NODE Number 1
NODE Address = 0000
```

The T500 has been designed to work with the TN4e temperature sensor node. Although the TN4e has been specifically designed to work with NTC type temperature sensors, it will also work with PTC temperature sensors and thermostatic switches. The switch input is intended to work with voltage free contacts either normally open or normally closed in operation and therefore is not restricted to temperature applications and can be used with other sensors, such as the TS1V4CA TouchSwitch or signal relays. NTC type temperature sensors are designed to provide a continuously variable temperature indication. PTC temperature sensors are designed to provide a fixed temperature trip point for temperature monitoring and the contact sensing provides programmable contact change detection from a thermostat or other contact device. Below is an example of the setup procedure for each type of sensor.

4.1.1 HOTBUS 2 Node number.

The T500 elite is capable of being connected to 64 TN4e Nodes and therefore it is essential to determine which of the 64 nodes the information is referring to. Each TN4e node is manufactured with a unique serial number. The last four digits of the serial number are the address of the node. If 683/1023 is the serial number then 1023 is the node address. As each node supports 4 sensors it is important to carefully record which is sensor 1, 2, 3 and which is sensor 4. Before attempting to setup the T500 elite you should plan your sensor network and record the following for later use. Note that all sensors connected to the node can be of different types, see page 13

Node Address: e.g. 1023

Sensor types for the node: NTC, PTC, or CNT (Contact)

The names for sensors 1-4 (20 characters maximum, see sensor name editing on page 16)

4.1.2 Node Setup.

When entering the NODE SETUP mode either for the first time or when editing, the following screen will appear. The first line shows you that you are in the MODE SETUP.

```
- NODE SETUP -
NODE Number 1
NODE Address = 0000
```

The second line displays the names of the chosen node (Node 1 by default) and the third line shows the address of the node. The display cursor should be placed to the left of the words 'NODE Number 1'. At this part of the setup procedure, you can use the UP (▲) and DOWN (▼) keys to move your way through the list of 64 nodes. Un-programmed nodes will by default display with a node address of 0000. When you have selected the node you wish to edit, press the SET key.

The cursor will now move to the address portion of the node details. You can now use the UP (▲), DOWN (▼), LEFT (◀) or RIGHT (▶) keys to edit the node address. When you are satisfied that the number being displayed is correct, press the **SET** key to save this number and move on to the next entry.

```
- NODE SETUP -
NODE Number 1
NODE Address = 1234
```

The T500 then displays the details associated with each of the 4 sensors that make up the TN4e. Using the (▲) and (▼) you must first select which of the 4 sensors you want to edit. If this is the first time you have edited this node then all the sensors will be NTC type otherwise the information for each sensor will be displayed in turn as you scroll through the four sensors. In order to help you identify the sensor more clearly, each sensor has a unique name. The default names for the first 4 sensors (Node 1) is “Sensor Number 1..4” and the second set of 4 sensors (Node 2) is “Sensor Number 5..8” and so on until the sensors for node 64 which are “Sensor Number 253..256”. Later we will examine a method by which the sensor names may be changed but for now we will assume that we are using the default sensor names.

```
Sensor Number 1
TYPE= NTC : Relay 00
RELATIVE ALARM 30
ABSOLUTE ALARM 176
```

```
Sensor Number 2
TYPE= NTC : Relay 00
RELATIVE ALARM 30
ABSOLUTE ALARM 176
```

```
Sensor Number 3
TYPE= NTC : Relay 00
RELATIVE ALARM 30
ABSOLUTE ALARM 176
```

Once you have decided which of the 4 sensors you wish to edit press the SET key. The cursor will now move onto the sensor type (NTC in our example opposite). You can change this option as much as you wish by pressing the (▲) and (▼) keys. As you change the sensor type the information on the display will change to reflect the requirements of each sensor type. Once you have decided on the sensor type press the SET key to move on to the entry detail for that specific sensor.

```
Sensor Number 4
TYPE= NTC : Relay 00
RELATIVE ALARM 30
ABSOLUTE ALARM 176
```

4.1.3 Setup for NTC sensors.

If you selected to use the NTC type of sensor then the setup screen should look like it does on the right. The top line shows the name of the sensor, the second line shows the chosen sensor type and the alarm relay number. The third line shows the relative temperature alarm level and the fourth line shows the absolute temperature alarm level.

```
Sensor Number 4
TYPE= NTC : Relay 00
RELATIVE ALARM 30
ABSOLUTE ALARM 176
```

The flashing cursor will be placed on the High Temperature Alarm relay. If setting up for the first time then the value will be 00 otherwise it will display the value set previously. The T500 is equipped with an internal alarm warning relay. Any alarm condition will result in this relay operating. The T500 can also have 4 R500 elite relay interface units connected to it. Each R500 is equipped with 16 interface relays providing a maximum of 64 relays all of which can be utilised as part of the temperature monitoring system. If the High Temperature Relay is set to 00 then only the internal warning relay will operate, however, if you set the relay to a

```
Sensor Number 4
TYPE= NTC : Relay 01
RELATIVE ALARM 30
ABSOLUTE ALARM 176
```

number between 1 and 64, then the associated R500 alarm zone relay will also operate. You can adjust the number of the relay by using the keyboard as described on page 7. When you have entered your chosen relay number press SET to continue.

The cursor will now move down to the 'Relative Alarm 30' prompt. The relative temperature alarm provides the ability to set an alarm level which is relative to the ambient temperature of the system. This provides a close temperature control for the T500 Elite. If the current ambient temperature is 70°F then setting the relative temperature for sensor 1 to 30°F will result in the alarm level of 70°F+30°F = 100°F. If the ambient temperature was to rise to 80°F then the relative temperature alarm would be 80°F+30°F = 110°F in other words the actual alarm is always 30°F above the current ambient. Setting the relative alarm value to 0°F results in the close temperature controls being disabled. A maximum relative temperature alarm limit of 90°F (above ambient) is applied to this feature. The factory default level is 30°F. This alarm type only applies to the NTC sensors. The ambient temperature is measured by a separate NTC temperature sensors located on the TN4e node circuit board and applied specifically to the 4 sensors associated with the node. When you have completed your entry, press SET to continue

```
Sensor Number 4
TYPE= NTC : Relay 00
RELATIVE ALARM 30
ABSOLUTE ALARM 176
```

The cursor will now move down to the 'Absolute Alarm nnn' prompt. If setting up for the first time then the value will be 176°F otherwise the value will be as previously set. This provides an adjustable absolute alarm level for the sensor and can be adjusted between 000°F and 230°F. When the measured temperature exceeds this setting, the T500 will generate an alarm in accordance with the relay settings above. This alarm operates independently of the relative alarm setting and has no relationship with the ambient temperature. It is provided for use when the ambient temperature measurement can not be relied upon or when you require a second and secure alarm. If the ambient sensing system is not set or has failed to operate correctly, then the absolute alarm will protect the system against high temperatures. If a Relative alarm was set to 30°F above ambient and the Absolute alarm was set to 150°F, then the alarm will operate when the measured temperature exceeds 150°F irrespective of the Relative alarm settings. The factory default level is 176°F. When you have entered your chosen Absolute alarm level, press SET to continue.

```
Sensor Number 4
TYPE= NTC : Relay 00
RELATIVE ALARM 30
ABSOLUTE ALARM 176
```

Pressing the SET button completes the entry page but we sometimes make mistakes during entry of data or we need to edit more than one entry before moving on to do other things. Before the new information is finally saved for use you have a number of choices that you can make. Pressing the LEFT (◀) key saves the new information and returns you back to select a new node. Pressing the RIGHT (▶) key saves the information and returns you back to the sensor edit screen and the SET key just exits the setup mode saving any changes.

```
USE THE KEYS TO
< = Go to NODE edit
> = Go to SENSR edit
SET = Done with edit
```

Once you have pressed the (◀), (▶) or SET key, the information is saved in permanent memory so that the next time the T500 is powered up, these settings will automatically come into effect.

WARNING: If you do not press a key for 1 minute, the edit menu will close and any data entered will be lost.

4.1.4 Setup for PTC sensors.

If you selected to edit the PTC type of sensor then the screen should look like it does on the right. The top line shows name of the sensor. The second line shows the chosen sensor type and the alarm relay number. The third and fourth line is blank. PTC sensors do not require an alarm temperature as they are designed to work at fixed alarm temperatures (see page 13).

```
Sensor Number 16  
TYPE= PTC : Relay 00
```

The flashing cursor will be placed on the chosen alarm relay. If setting up for the first time then the value will be 00 otherwise the value will be what was set previously. The T500 is equipped with an internal alarm warning relay. Any alarm condition will result in this relay operating. The T500 can also have 4 R500 elite relay interface units connected to it. Each R500 is equipped with 16 interface relays providing a maximum of 64 relays all of which can be utilised as part of the temperature monitoring system. If the High Temperature Relay is set to 00 then only the internal warning relay will operate, however, if you set the relay to a number between 1 and 64, then the associated R500 alarm relay will also operate. You can adjust the number of the relay by using the keyboard as described on page 7. When you have entered your chosen relay number press SET to continue.

```
Sensor Number 16  
TYPE= PTC : Relay 31
```

Pressing the SET button completes the entry page but we sometimes make mistakes during entry of data or we need to edit more than one entry before moving on to do other things. Before the new information is finally saved for use you have a number of choices that you can make. Pressing the LEFT (◀) key saves the new information and returns you back to select a new node. Pressing the RIGHT (▶) key saves the information and returns you back to the sensor edit screen and the SET key just exits the setup mode saving any changes.

```
USE THE KEYS TO  
< = Go to NODE edit  
> = Go to SENSR edit  
SET = Done with edit
```

Once you have pressed the (◀), (▶) or SET key, the information is saved in permanent memory so that the next time the T500 is powered up, these settings will automatically come into effect.

WARNING: If you do not press a key for 1 minute, the edit menu will close and any data entered will be lost.

4.1.5 Setup for CNT (contact) sensing.

If you selected to edit the CNT type of sensor then the screen should look like it does on the right. The top line shows the sensor name. The second line shows the chosen sensor type and the alarm relay number. The third line shows the current alarm condition for the contact.

```
Sensor Number 16  
TYPE= CNT : Relay 00  
ALARM WHEN ON
```

The flashing cursor will be placed on the chosen alarm relay. If setting up for the first time then the value will be 00 otherwise the value will be what was set previously. The T500 is equipped with an internal alarm warning relay. Any alarm condition will result in this relay operating. The T500 can also have 4 R500 elite relay interface units connected to it. Each R500 is equipped with 16 interface relays providing a maximum of 64 relays all of which can be utilised as part of the temperature monitoring system. If the High Temperature Relay is set to 00 then only the internal warning relay will operate, however, if you set the relay to a number between 1 and 64, then the associated R500 alarm relay will also operate. You can adjust the number of the relay by using the keyboard as described on page 7. When you have entered your chosen relay number press SET to continue.

```
Sensor Number 16  
TYPE= CNT : Relay 22  
ALARM WHEN ON
```

Because contact conditions can be applied in one of two known states the 'ALARM WHEN' condition can be toggled to either 'OFF' or 'ON' by using the UP (▲) or DOWN (▼) keys. This means that if your contact is normally 'ON', you might want to alarm when it changes to 'OFF' or if it is normally 'OFF' you might want to alarm when it changes to 'ON'. This state can be set individually for each of the contact inputs.

```
Sensor Number 16  
TYPE= CNT : Relay 22  
ALARM WHEN ON
```

Pressing the SET button completes the entry page but we sometimes make mistakes during entry of data or we need to edit more than one entry before moving on to do other things. Before the new information is finally saved for use you have a number of choices that you can make. Pressing the LEFT (◀) key saves the new information and returns you back to select a new node. Pressing the RIGHT (▶) key saves the information and returns you back to the sensor edit screen and the SET key just exits the setup mode saving any changes.

```
USE THE KEYS TO  
< = Go to NODE edit  
> = Go to SENSR edit  
SET = Done with edit
```

Once you have pressed the (◀), (▶) or SET key, the information is saved in permanent memory so that the next time the T500 is powered up, these settings will automatically come into effect.

WARNING: If you do not press a key for 1 minute, the edit menu will close and any data entered will be lost.

4.1.6 Sensor Network Design.

The HotBus2 sensor monitoring system based upon the T500 has been designed to offer simplicity and flexibility. You can mix the TN4e node installation as freely as you like. It is not necessary to use consecutively numbered TN4e for the system to work. Neither is it necessary to assign the nodes to any logical sequence. If you leave holes in the setup information, for example if you only have three nodes you might assign them like this - Node 1 is address 1000, Node 3 is address 1097 and node 23 is address 1023 then the missing or blank entries are ignored and have no effect on the operation of the T500. It is however, strongly recommended that you consider assigning the Node numbers consecutively 01 – 64 as this makes monitoring the temperatures easier and entering useful and meaningful sensor name is easier. You may find it useful to leave small gaps in the system especially if you intend to add extra TN4e nodes at a later date, however, there is no association between the physical placement of the nodes and the order of programming in the T500 so you are free to place the nodes in any order. Experience has shown that you will benefit greatly by planning the system with some thought to how you intend to use the information. A common format for use is to assign each node to a section or area to be monitored and assign the sensors according the needs of that area, adding more nodes if necessary.

4.1.7 Alarm zoning.

Each TN4e node can read the state of 4 independent sensors. These sensors can be associated with an alarm relay. Alarm relay 00 (default) is the built in warning relay and operates for all alarm conditions. If the optional relay interfaces are fitted (R50016V345) then up to a further 64 alarm channels are available for the user. Setting the relay number for any of the sensors to between 01 and 64 will associate the alarm relay 01 to 64 to that sensor. Any number of sensors can be associated with an alarm relay. For example:

Node 1001	Sensor 1 = 00	T500 alarm warning relay only. (WR)
	Sensor 2 = 04	Optional alarm relay 4 + (WR)
	Sensor 3 = 01	Optional alarm relay 1 + (WR)
	Sensor 4 = 14	Optional alarm relay 14 + (WR)
Node 1003	Sensor 1 = 01	Optional alarm relay 1 + (WR)
	Sensor 2 = 02	Optional alarm relay 2 + (WR)
	Sensor 3 = 03	Optional alarm relay 3 + (WR)
	Sensor 4 = 04	Optional alarm relay 4 + (WR)

It can be seen from the examples above that a number of sensors can be zoned together, Node 1001 Sensor 3, Node 1003 Sensor 1 are both associated with alarm relay 1. Any one or both of these sensors, which exceed the programmed limits, will operate relay 1 of the R500 relay interface. Any alarm will always trigger the internal alarm relay of the T500 elite. Any number of sensors can be associated with an alarm relay in this way.

4.1.8 Temperature sensor types.

Two types of NTC sensor are available for use with the T500

Brass Body Version Steel Body Version

<u>Part No. (Europe)</u>	<u>Part No. (USA)</u>	<u>Temperature</u>
WDB10V34CA	WDB20V34CA	Max 230°F

PTC sensors have a fixed alarm level which is determined by the type of sensor. The table below lists some of the sensor types available.

Brass Body Version Steel Body Version

<u>Part No. (Europe)</u>	<u>Part No. (USA)</u>	<u>Temperature</u>
WDB11V34CA	WDB21V34CA	122°F
WDB12V34CA	WDB22V34CA	140°F
WDB13V34CA	WDB23V34CA	158°F
WDB14V34CA	WDB24V34CA	176°F
WDB15V34CA	WDB25V34CA	194°F
WDB16V34CA	WDB26V34CA	212°F

4.2 Normal Operation.

Once the initial setup has been performed and at least 1 TN4e has been connected to the system then the T500 will enter the normal monitoring mode. During normal operation, the T500 will continuously scan all of the programmed sensors and respond to their programmed alarm settings. This mode displays the status of a single sensor connected to the T500. The actual sensor being displayed can be selected by using the Up(▲) and Down(▼) arrow keys. During the normal sensor display the software is capable of showing any one of the 256 sensors, which may be available. As each TN4e node has 4 sensors connected to it, the display shows consecutively connected sensors. For example if you were to connect three nodes 1,2 and 3 to the T500 then the display will show the settings for sensors 1 to 12. If a sensor is connected and working correctly then its actual state will be displayed in either °C or °F if the sensor is an NTC type, NORMAL or HIGH if the sensor is a PTC type and ON or OFF if the sensor is a CNT type. If a sensor is not programmed (see the section on setting up the T500) then the display will show NTC type and <<<°F as the current temperature and 000°F as the ambient temperature. All 256 sensors can be displayed in this manner. As you scroll up or down through the sensors, the alarm zone number and alarm trip level or alarm condition associated with each sensor will update automatically on the screen. Although no restrictions are placed upon the order of programming for the nodes, it can be seen that it is to your advantage to programme them in a logical order. Three nodes programmed consecutively will result in the first 12 sensors being displayed. This makes it easy to choose the sensor, which you want to monitor. If you programme the nodes with holes in the sequence, 1,15 and 26 for example, then the associated sensors numbers will be 1..4 for node 1, 57..60 for node 15 and 101..104 for node 26. It can be seen that this is not an efficient way in which to programme the nodes as it takes a long time to scroll through the list to reach a programmed sensor.

Sensor Number 1 Temperature = 082°F Amb 070°F :Relay 10 Rel 30: Abs 150: NTC
Sensor Number 2 Temperature = 080°F Amb 070°F :Relay 10 Rel 30: Abs 150: NTC
Sensor Number 3 Contact State = OFF Alarm = ON :Relay 11 Sensor Type = CNT
Sensor Number 4 Contact State = OFF Alarm = ON :Relay 12 Sensor Type = CNT
Sensor Number 5 Temperature = NORMAL Alarm Relay = 27 Sensor Type = PTC
Sensor Number 6 Temperature = NORMAL Alarm Relay = 27 Sensor Type = PTC
Sensor Number 200 Temperature = <<<°F Amb 000°F :Relay 00 Rel 30: Abs 176: NTC

When power is applied details for sensor 1 will be displayed by default. While displaying the detail for sensor 1, pressing the Down(▼) key will cause the T500 to display the details for sensor 256. The reverse of this is also permitted. When displaying the details for sensor 256, pressing the Up(▲) key will cause the T500 to display the result in the details for sensor 1.

4.3 Sensor Alarm Detection and Display.

Each programmed node will have its status constantly updated on a first to last basis. As the sensor data is read from a node, the status is compared with the programmed alarm setting. If the actual status matches the programmed alarm condition an alarm is generated. If the alarm zone was programmed at the default 00, then only the T500 alarm relay will operate. If the alarm zone was programmed with a number between 01 and 64, then the associated alarm relay on the optional R50016V345 relay interface will operate as well as the T500 warning relay. When an alarm is detected, the display changes to show the details for the sensor, which generated the alarm. Up to 20 alarms can be detected and displayed in this manner. The display will toggle between the original NORMAL display as described above and the ALARM display at approximately three second intervals. If for example three sensors alarmed the display would show the TEMPERATURE DISPLAY followed by the ALARM for the first alarmed sensor then the TEMPERATURE DISPLAY followed by ALARM for the second alarmed sensor followed by the TEMPERATURE DISPLAY then followed by ALARM for the third alarmed sensor. The process would then repeat with a three second delay between screens. The bottom line of the ALARM screen shows the total number of detected alarms and which of those alarms is currently being displayed. NTC sensors are monitored for fault conditions. As well as reporting the over temperature alarm the T500 will also show when it detects an NTC sensor which it believes to be open or short circuit. These alarm conditions are displayed in much the same way as the other alarms listed

```
*ALARM* DETECTED ON
Sensor Number 1
OVER SET TEMPERATURE
ALARM 01 OF 05
```

```
*ALARM* DETECTED ON
Sensor Number 3
CONTACT CHANGE ALARM
ALARM 02 OF 05
```

```
*ALARM* DETECTED ON
Sensor Number 6
HOT BEARING ALARM
ALARM 03 OF 05
```

```
*ALARM* DETECTED ON
Sensor Number 12
OPEN SENSOR FAULT?
ALARM 04 OF 05
```

```
*ALARM* DETECTED ON
Sensor Number 24
OVER TEMPERATUR RANGE
ALARM 05 OF 05
```

In order that the system maintains integrity at all times all programmed nodes are monitored for communications faults. If a programmed node is disconnected by unplugging it from the communication system or if a node should fail a communications alarm will be generated and the T500 internal warning relay will be operated. The remaining nodes and their sensors will continue to operate as normal and for as long as the HOTBUS cable integrity is maintained.

```
*ALARM* DETECTED ON
NODE ADDRESS 1023
COMMUNICATION ERR.C5
ALARM 01 OF 01
```

Any alarm relays associated with the disconnected node will not be updated and no further alarms can be generated for those sensors. If the communications problem is resolved then the alarm will be cleared and the monitoring of that node will continue as normal.

There are 5 communication errors reported by the T500 for each Node connected and they are C1 to C5. C5 is the most frequently seen communication error as this is the result of a complete failure of communication with the node. If a node becomes unplugged or fails in some way then this is the error that you would normally expect to see. The other errors usually occur when there is a problem with the installation of the cable or when there is

electrical interference which is disrupting the communication system. A chapter is included later to offer advice should communications errors happen in you installation.

4.4 Alarm Log

The T500 is equipped with a simple ALARM LOG. Every alarm detected by the T500 will be entered into this log no matter how briefly the alarm exists. This is a useful feature for finding troublesome intermittent alarms. The log has space for 20 alarms and the newest alarm is always at the top of the list at position 1. As the alarms are entered into the alarm log, the log is pushed down by 1 each time making room for the latest alarm to be entered. Eventually, when the log is full the oldest alarm (alarm 20) will be discarded. Using the ALARM LOG option in the main menu, you can examine the log at any time. The log is erased when power is removed from the T500.

4.5 Warning Relay Cancel (Acknowledge).

If during any alarm condition and whilst the T500 internal alarm warning relay is in operation, the SET key is pressed, then the internal alarm relay and LED warning will be cancelled. If the alarm condition persists, after a programmed period of time (see menu options) the warning relay and LED indicator will operate again. The warning alarm may be cancelled in this way any number of times.

4.6 Alarm condition stop. (Shut Down)

The T500 is not equipped with any shutdown or stop relays. It was intended that the internal alarm relay be used for audible or visual warnings. However, providing that the correct ratings are observed, there is no reason why the relay cannot be used for indirect control of a stop/start circuit. The T500 relay operates as a normally open relay and will close contact when an alarm is generated. If you require greater flexibility in your alarm/stop circuits then we recommend the use of the optional relay interface R50016V345. This unit provides 16 additional relays each with a single pole changeover contact rated 250 VAC @ 5Amp, which are more suited to use in interface applications. Four R50016V345 relay interface units may be connected to a T500 elite sensor monitoring system providing a total of 64 relays. None of the relay contacts are 'SAFETY' contacts and as such must not be relied upon for emergency stop purposes.

4.7 T500 Menu selection.

During normal operation of the T500 pressing the SET key will select the main menu. The main menu has 3 options SETUP, DOWNLOAD and ALARM LOG. Pressing the LEFT (◀) key selects SETUP, pressing the RIGHT (▶) key selects the DOWNLOAD option, pressing the UP (▲) key selects the ALARM LOG option and pressing the SET key cancels the menu and returns the T500 to normal operation.

```
MAIN MENU:-  
< = SETUP  
> = DOWNLOAD  
^ = Alarm Log
```

Selecting SETUP from the main menu allows 2 further selections to be made as described in the box to the right. Selecting NODE SETUP will take you to the main node setup area as described on page 8 and selecting T500 SETUP will select the menu option shown below.

```
< = Node Setup  
> = T500 Setup  
  
SET = EXIT
```

The T500 SETUP menu has three options. Selecting the T500 ADDRESS allows you to assign a unique number between 0, 1 and 2 to each T500. This feature is used when

```
< = T500 Address  
> = Display in °F  
^ = Warning Relay  
SET = EXIT
```

the T500 is used in conjunction with the F500 FieldBus communications interface (see the chapter titled additional equipment).

Selecting the ‘**Display In °F**’ option will toggle this from °F to °C to °F each time the key is pressed. This option is used to set the T500 to display temperature information and alarm settings in °F or °C.

WARNING: We strongly recommend that you set this option **BEFORE** you set up any NTC node alarms. Temperature alarms are done on the basis of a straight comparison between the value measured and the programmed alarm level. Setting the alarm level to 40° means either °C or °F depending upon which option has been selected here. Setting the alarm level to 40°C and then switching to display in °F changes the alarm level to 40°F which may already be below the current temperature which would then result in an immediate temperature alarm.

Selecting ‘**Warning Relay**’ allows an adjustment to the ALARM WARNING REACTIVATION TIMER. This is the timer used to reactivate the T500 alarm warning relay and LED when any existing alarm warning has been cancelled. The default value is 3 minutes and values between 0 and 5 minutes can be set in 1 minute increments by pressing the UP(▲) and DOWN(▼) keys. If the SET button was pressed to reset the alarm warning condition and a new alarm occurs during the timing period, then the alarm warning relay will automatically reactivate and the timer will be reset. Setting this value to 0 means that the warning will NOT reactivate until a new alarm has occurred.

```
ALARM WARNING
REACTIVATION TIMER
SET TO 03 MINUTES
```

4.8 Sensor name editing.

In order that the information displayed on the T500 LCD screen is as meaningful as possible, the T500 is equipped with the ability to display a name associated with each of the 64 sensors. The T500 is supplied with a default set of sensor names, Sensor 1, Sensor 2....Sensor 63, Sensor 64. PC software is available to allow the editing and then downloading of the sensor names to the T500 Elite. Each name is limited to 20 characters in length and once edited; the names can be saved on the PC for use again later.

4.9 Downloading.

This option is currently under development and is included in the manual for reference only. Selecting DOWNLOAD will have no effect on the operation of the T500 system.

If DOWNLOAD is selected from the main menu then the T500 will stop monitoring the sensors and enter the download mode. This mode allows you to download useful sensor names from a PC via the sensor naming utility software. If this option is selected by mistake pressing the SET key will abort the download without any changes taking place. If download is selected and download fails for whatever reason, then the download will automatically abort after 1 minute. Pressing SET during a download will abort the download at the next available point and therefore data downloaded to that point will still be valid. The T500 must be connected to the PC through the standard RS232 serial port using a communications lead with the following connections.

```
DOWNLOADING ..
PRESS SET TO
ABORT
```

RS232 connections.

Computer connector pin 1 should be connected to the T500 RS232 0 Volt terminal

Computer connector pin 2 should be connected to the T500 RS232 TX terminal

Computer connector pin 3 should be connected to the T500 RS232 RX terminal

The above connections assume that the computer is equipped with a standard 9 pin D-sub serial connection.

The PC software has been designed to allow you to give names to all 256 sensors which apply more appropriately than the default name Sensor Number 1, Sensor Number 2... Each name is limited to 20 characters in length and can be any combination of letters numbers and spaces. The 20 character limit is applied because the display used on the T500 has lines of 20 characters and a single line has been allocated to the displaying of the sensor name. Please refer to the manual accompanying the PC software for further detail of its use. To download the sensor names run the PC software, load your saved name file or if this is the first time then edit your names and save them; connect the PC to the T500 as described above and click the "TEST CONNECTION" button on the PC screen. This will check the communications connections with the T500 and ensure that the software is correctly set up. Using the T500 menu as described above select DOWNLOAD. Now click the DOWNLOAD button on the PC screen. The names for the 256 sensors will be downloaded in order to the T500. Each downloaded name is checked for errors and the T500 confirms that the data is valid before the next name is downloaded. In order to help keep you informed of the progress of the download the T500 will show the number of the sensor that was most recently successfully downloaded. The PC software will also display confirmation of the download process. If an error is detected then the download will be aborted. Any names that have been successfully downloaded before the error will be retained by the T500 and only the data following the error will be lost. If a download is terminated by an error then the download can be started again immediately by clicking the DOWNLOAD button on the PC screen and the download will begin from the start of the process. If the download is unattended and fails to complete the software will automatically time out and return back to the normal monitoring state after 1 minute. The download can be manually aborted at any time by pressing the SET key on the T500, this will bring the download to a stop at the end of the current name. When a download is complete the T500 will display a completion message for 2 seconds and then it returns back to the normal operation mode.

CHECKLIST

For problems after initial start-up

1. Is there excessive interference on the electrical power supply? Power conditioners and surge (spike) suppressor may have to be fitted.
2. Has the wiring for the Sensors been routed away from power cables? See paragraph 3.
3. Is the T500 Elite circuit properly grounded?
4. Is the Micro-processor control unit overheating, if so mount in temperature-controlled environment of maximum temperature 104°F (40°C).
5. Check that high powered ‘Walkie Talkie’ radios are not operated immediately near the T500 Elite control unit or Sensors as this will affect the performance.
6. Check that the communications/power cable is connected correctly and in accordance with DRG ‘D’, ‘H’ and ‘J’.
7. If the T500 display shows only information similar to this example and does not update the temperature on screen then you are attempting to run the T500 without having configured sensors first. This can happen when you pressed SET to exit the setup screen without first saving any configuration. To clear this problem, remove power from the T500, wait approximately 5 seconds and then re apply power. The T500 should now enter the initial set up mode as described in section 4.1.

```
Sensor Number 1
Temperature = <<<°F
Amb 000°F :Relay 00
Rel 30: Abs 176: NTC
```
8. Have you set the optional R50016V345 address switch correctly?
9. If you are using NTC sensors have you set the Relative and/or Absolute alarm levels **ABOVE the NORMAL** working conditions for the sensor.
10. If you have programmed an NTC sensor and do not have a sensor connected, then an open circuit sensor alarm will occur. Unused sensors on a TN4e should be programmed as CNT type, see 11 below.
11. Ensure that any unused CNT inputs are programmed as ‘ALARM WHEN ON’ to avoid unexpected alarms.
12. Ensure that any unused PTC inputs have a wire link connected across the sensor terminals to avoid unexpected alarms.

5. CONTACT INFORMATION

**BRAIME ELEVATOR COMPONENTS LIMITED
HUNSLET ROAD ♦ LEEDS LS10 1JZ ♦ ENGLAND**

Web: <http://www.braime.com> ♦ Email: elevators@braime.co.uk

Tel. +44 (0) 113 246 1800 ♦ Fax. +44 (0) 113 243 5021

4B COMPONENTS LTD

729 SABRINA DRIVE ♦ EAST PEORIA, IL 61611-3578 ♦ USA

Web: <http://www.go4b.com> ♦ Email: go4b@aol.com

Tel. 309 698 5611 ♦ Fax. 309 698 5615

SETEM

9 ROUTE DE CORBIE ♦ 80800 LAMOTTE WARFUSEE ♦ FRANCE

Web: <http://www.setem@setem.fr> ♦ Email: setem@setem.fr

Tel. (33) 03 22 42 32 26 ♦ Fax. (33) 03 22 42 37 33

4B SUDAMERICA S.A.

ARCOS 2967 ♦ 1429 BUENOS AIRES ♦ ARGENTINA

Web: <http://www.go4b.com> ♦ Email: 4bsa@go4b.com

Tel. (54) 114 702 2364 ♦ Fax. (54) 114 701 5075

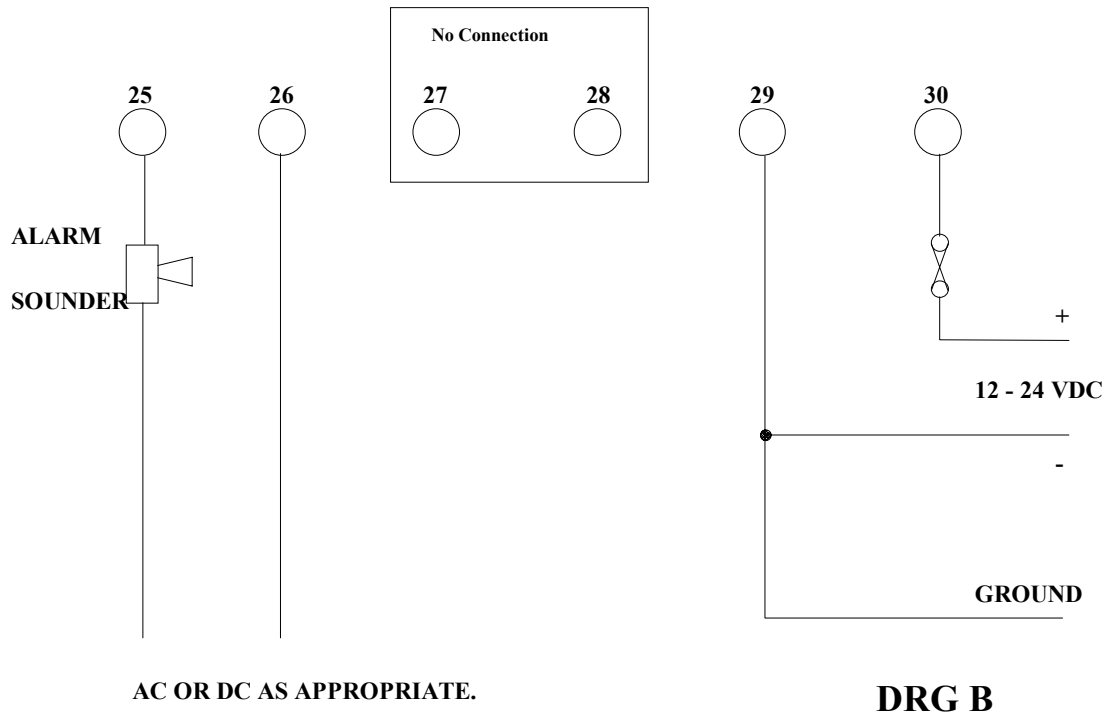
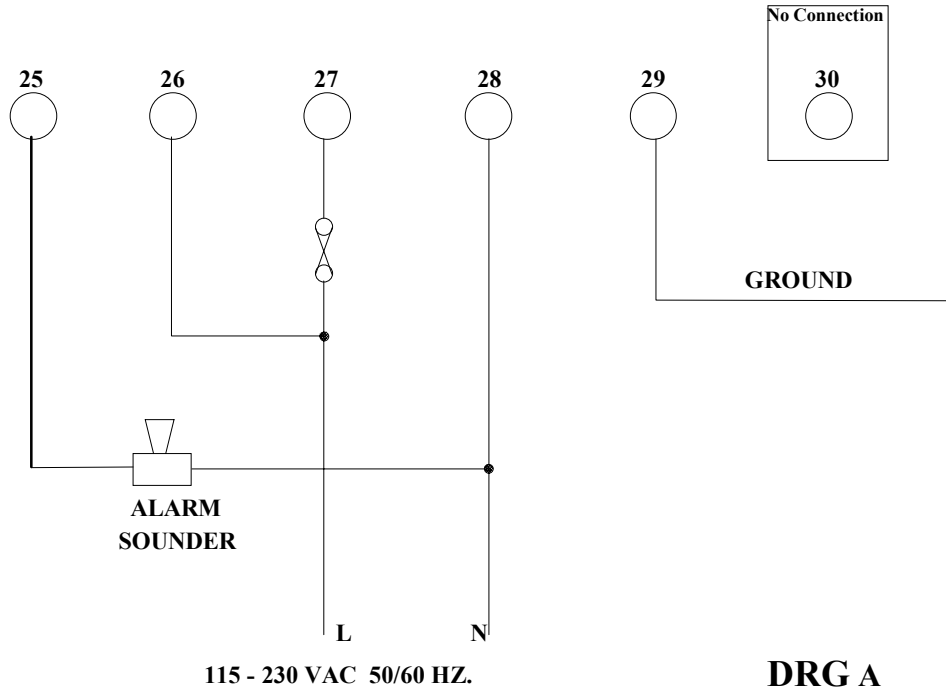

T500 Elite, supply connection details.

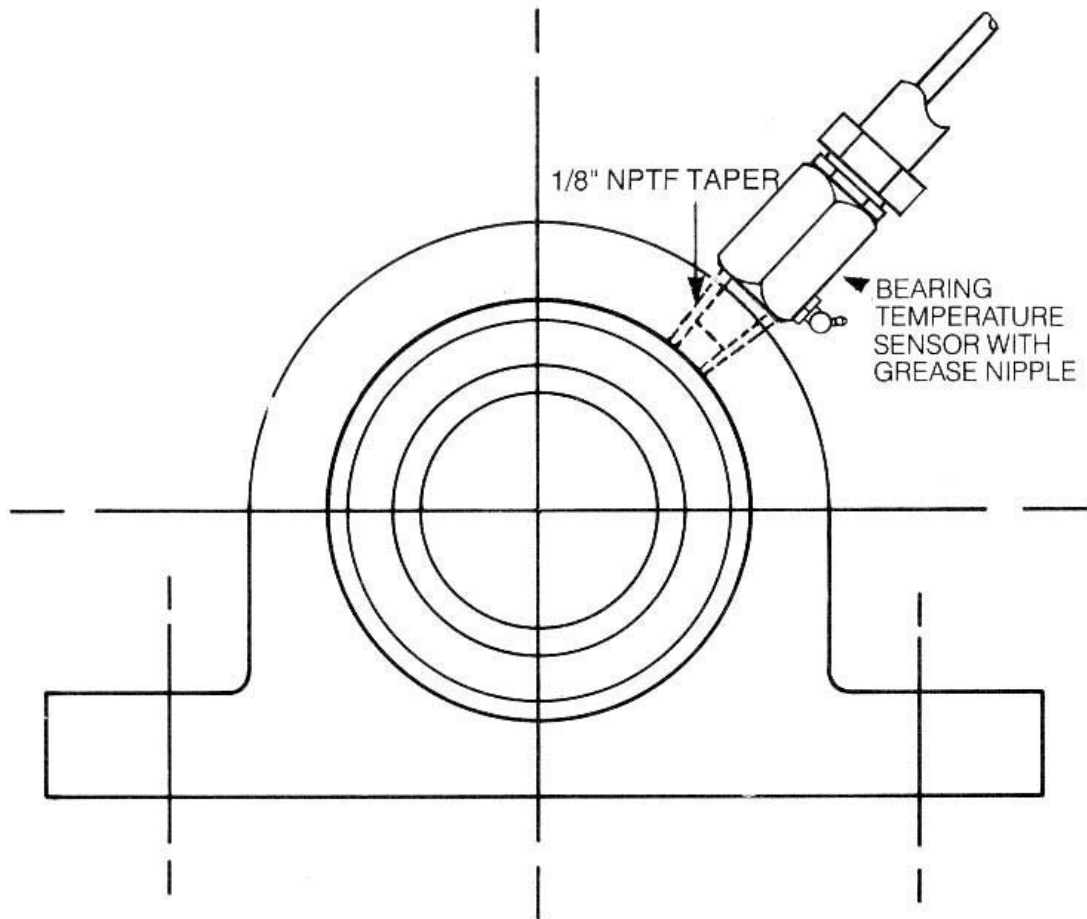

FITMENT TO BEARING OF TEMPERATURE SENSOR

NOTE

The special temperature sensor probe for use in a Class II Division 1 location has a connection for liquidtight flexible metal conduit.

DRG. 'C'

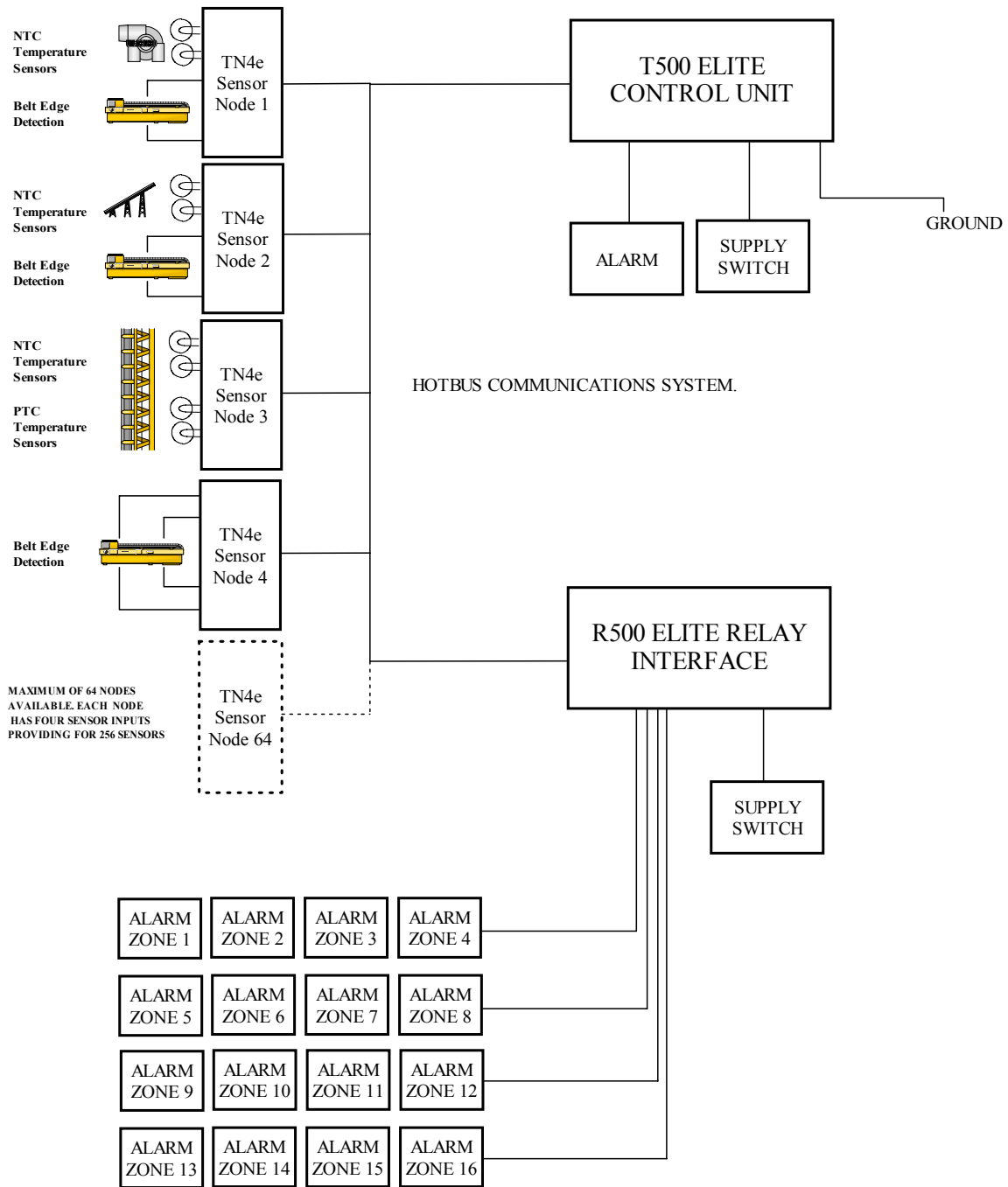

BLOCK DIAGRAM AND SENSOR WIRING

DRG. 'D'

R500 RELAY INTERFACE.
RELAY CONNECTION DETAILS.

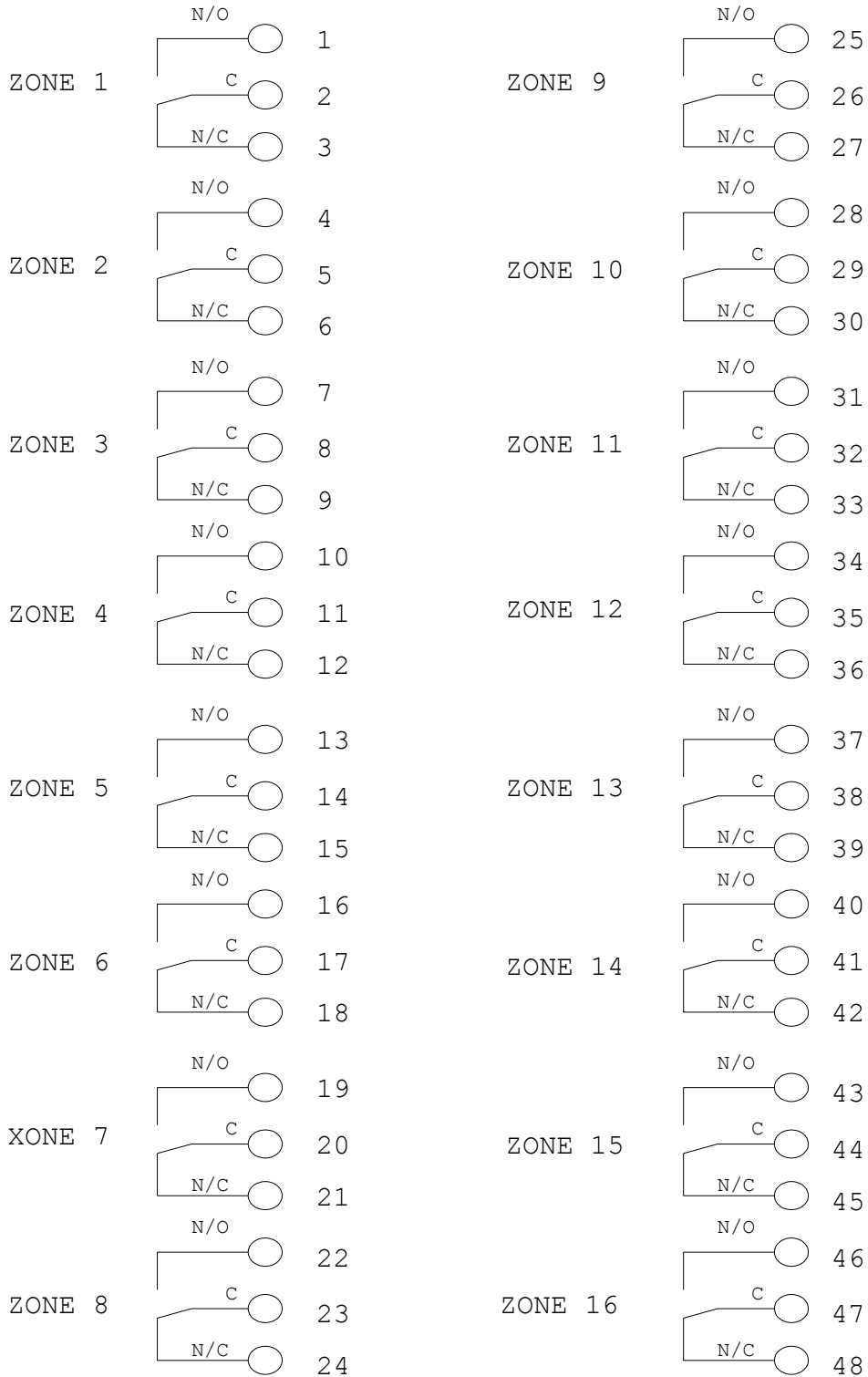

CONTACTS RATED AT 5A 240v AC

DRG'E'

**R500 RELAY INTERFACE
POWER CONNECTIONS**

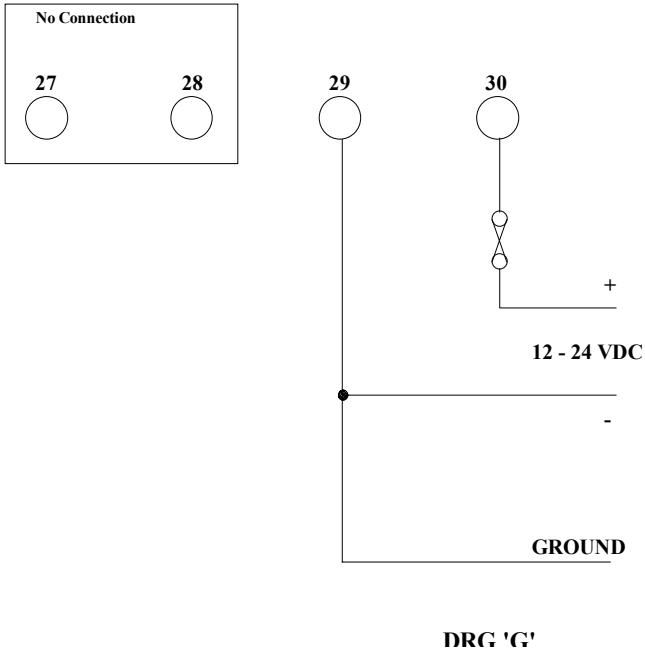
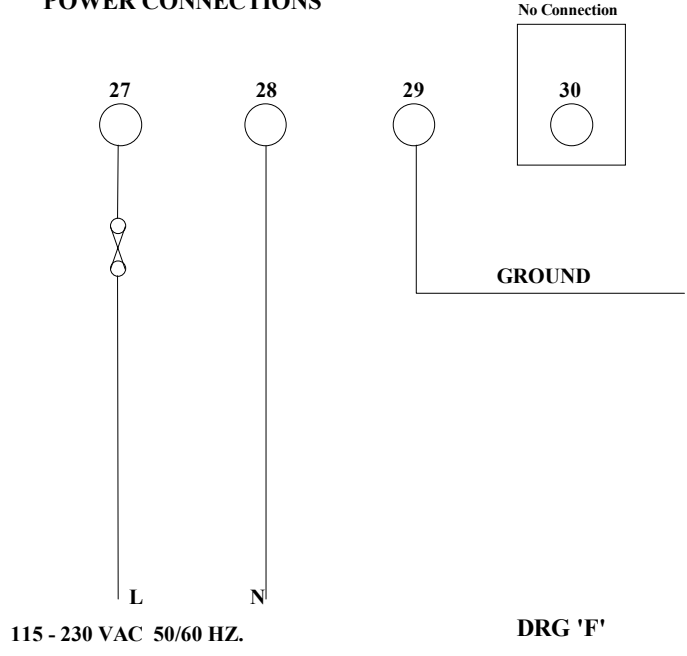

T500/R500 HOTBUS CONNECTIONS

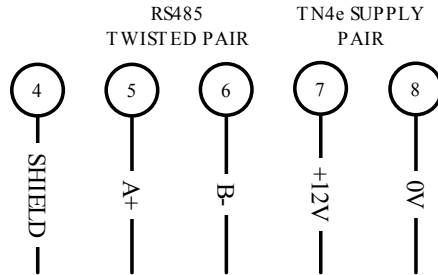

DRG 'H'

TN4e HOTBUS CONNECTIONS

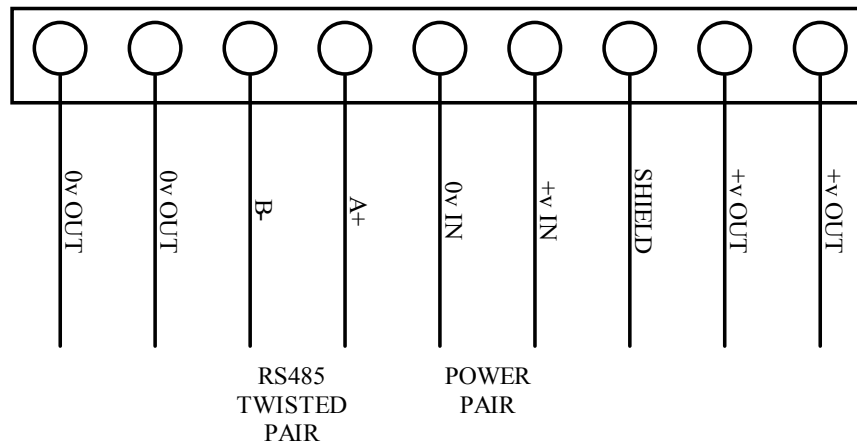

TN4e SENSOR CONNECTIONS

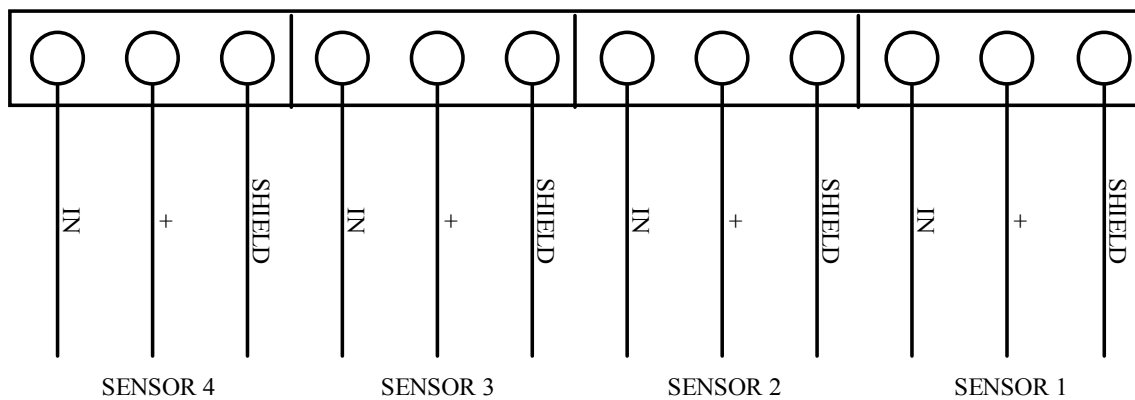

DRG J