

INDUCTIVE PROXIMITY SENSOR

Approved for dust explosive atmospheres
Zones 20, 21 & 22

APPLICATION

Detects the presence or absence of materials. Is used for monitoring the speed of machinery via a speed module or PLC

FEATURES

- ▶ Multi-voltage power supply 24-240V AC/DC
- ▶ 2-wire – PLC compatible
- ▶ Protected to IP 65
- ▶ M30 x 1.5 ISO threaded body for mounting & adjustment
- ▶ LEDs showing output state
- ▶ 12mm detection range
- ▶ ATEX & IECEx certified according to norm EN 50281-1-1
Ex II 1D T100°C IP65 – ZONE 20

PART NUMBERS/OPTIONS

- ▶ P3001V10AI – Contact Normally Open
- ▶ P3002V10AI – Contact Normally Closed
- ▶ WG1-8A-BR – Whirligig combined target/bracket/guard

CONNECTIONS

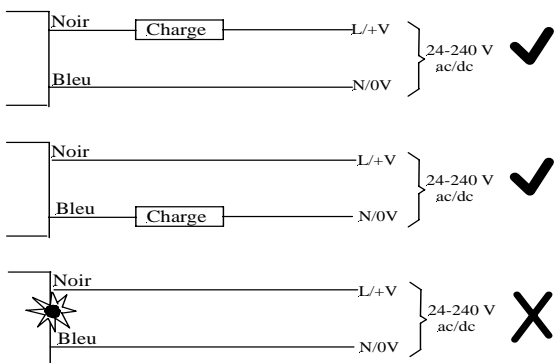

P3001V10AI or P3002V10AI



ATEX-Approved
Ex II 1D T100°C-IP 65-ZONE 20

IECEx

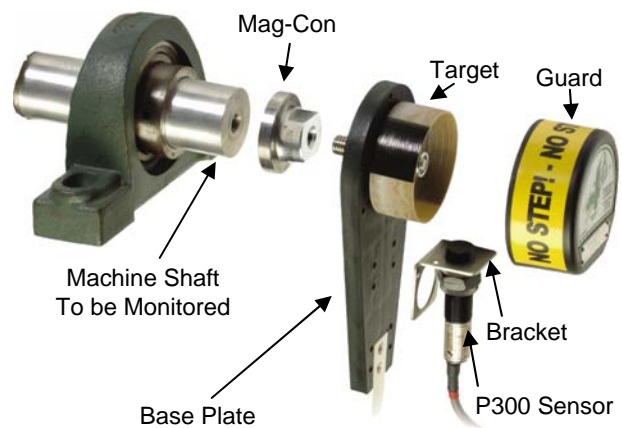

P300 Inductive Sensor shown with optional Whirligig and Mag-Con

(Used for simple and reliable installation on shaft speed monitoring applications)

Detailed specification, wiring diagrams and installation/operating instructions available immediately upon request.

Please refer to instruction manual for correct installation.
Information subject to change or correction. June 2006.

TECHNICAL SPECIFICATIONS		
Type	P3001V10AI	P3002V10AI
Power Supply	24-240V ac/dc	
Output	Normally Open	Normally Closed
Cable	2 m x 2 wires	
Max. Frequency		
Sensitivity	Detects up to 12mm	
Volt drop	8V max	
Temperature	-15°C to + 50°C	
Min. current	1,6mA	
Protection	IP 65	
Switching capacity	200mA	
Enclosure	Moulded polycarbonate ISO M30 X 1,5 mm	
Approvals	Atex EX II 1D T100°C	
LED	Green: sensor under tension	
	Red: target detected	

DIMENSION

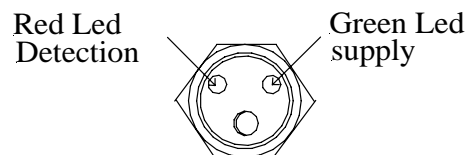
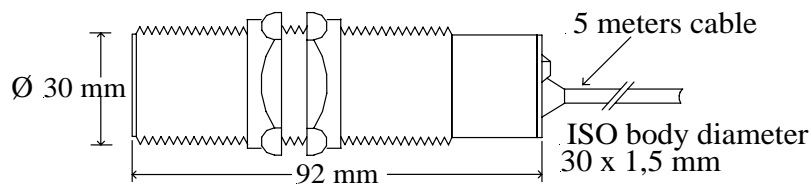

OUTPUT TYPE

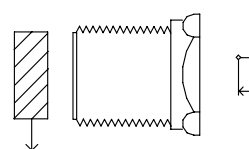
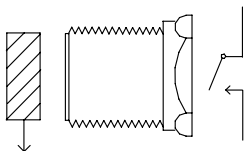

P3001V10AI

P3002V10AI

Please refer to instruction manual for correct installation.
 Information subject to change or correction. June 2006.