



SOCIETE D'ETUDES DE TECHNIQUE DE MANUTENTION

9 route de Corbie – 80800 LAMOTTE-WARFUSEE
 Tél :03 22 42 32 26 Fax :03 22 42 37 33
 S.A.R.L AU CAPITAL DE 100.000 F.-SIRET 311 020 523 00024-T.V.A FR 54311020523

ATEX Approved Inductive Proximity Sensor Type : P1002V10A

Dimensions - mm

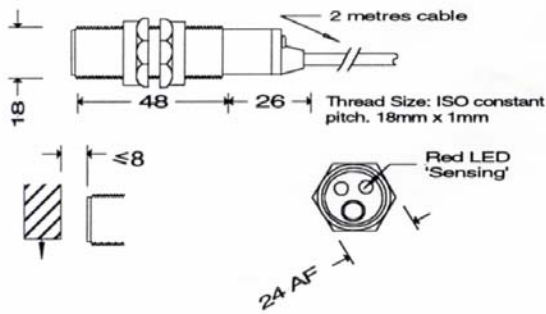

Protection

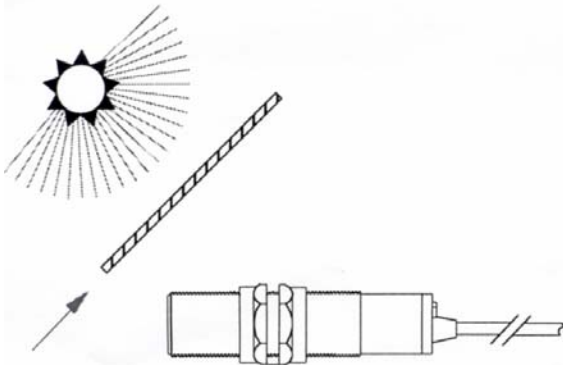

Approval



Approval No:
Baseefa03ATEX0589X

Category:
EXII 1D T100°C Tamb -15°C to +50°C IP65

Connections

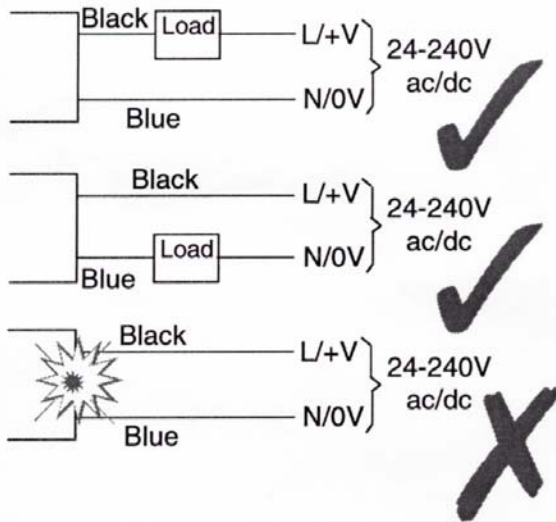

Output Mode

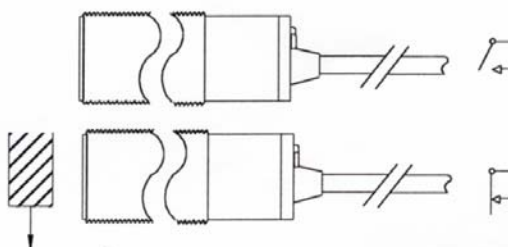

Specification

Supply V 24-240V ac/dc.
 I. min ≤ 1 mA.
 V. drop 8V max.
 Output Rating .. 200 mA max.
 Max. Speed 100 Hz.