



SOCIETE D'ETUDES DE TECHNIQUE DE
MANUTENTION

9 route de Corbie – 80800 LAMOTTE-WARFUSEE
Tél :03 22 42 32 26 Fax :03 22 42 37 33
S.A.R.L AU CAPITAL DE 100.000 F.-SIRET 311 020 523 00024-T.V.A FR 54311020523

ATEX Approved Inductive Proximity Sensor Type : P1001V34A

Dimensions - mm

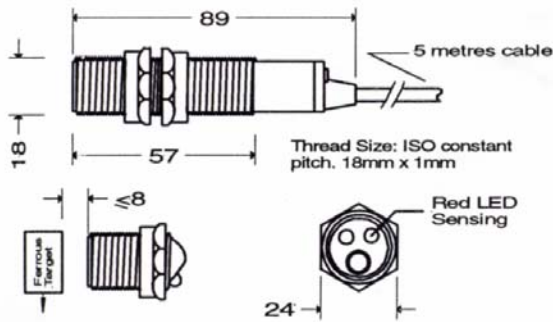

Connections:-
npn connection

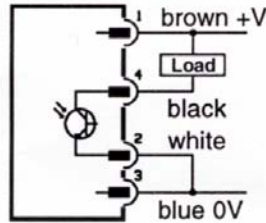

pnp connection

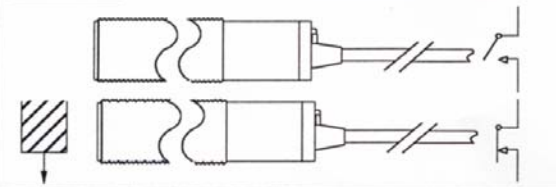
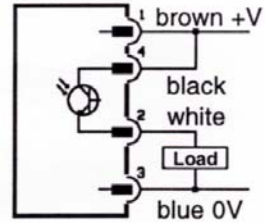

Protection

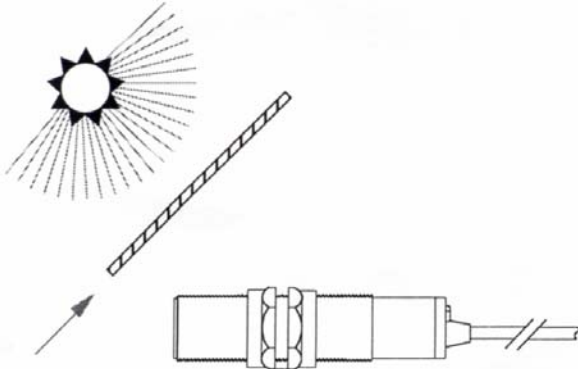

npn connection

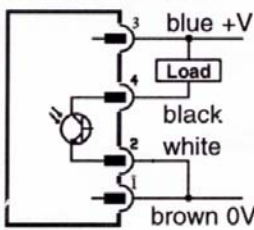

pnp connection

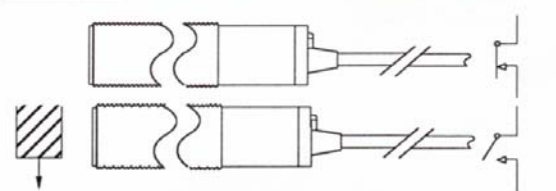
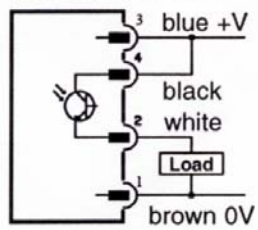

Approval



Approval No:
Baseefa03ATEX0589X

Category:
EXII 1D T100°C Tamb -15°C to +50°C IP65

Specification

Supply V 10-30V dcc.
Output Opto-isolated transistor, npn or pnp use.
Output Rating .. 100 mA 30V dc max.
Max. Speed 200 Hz.

>_ID_ETMOATEXMAN 644-050(A)