

OUTPUT LED FAULT CODE:

Orange: Programming not accepted, unit has defaulted back to previous programme settings and requires re-programming.

Red: Follow procedure "Recalibration for a different setting". If the output LED remains red, contact your supplier.

BASIC FAULT FINDING

- 1) Input light does not illuminate.
Check that you have a supply of the correct value across the brown and blue wires. Slide a screwdriver blade across the face of the sensor, the input light should flicker. If not, contact your supplier. If it does, move the front face nearer the target and check target size is as specified under "Installation".
- 2) Input light stays on permanently.
Either increase the gap between the target and the shaft, or between the target and the sensor face.

ELECTRICAL SPECIFICATION

Supply ————— 110V ac or 220V ac 50/60 Hz or 24V ac/dc (specify when ordering).

Fusing ————— Unit should be wired to a supply rated at 5A maximum.

Speed Range ——— 10-3600 PPM. (Pulses Per Minute).

Operating Range — 9mm max. (ferrous) 6mm max. (non-ferrous)

Target ————— Ideally ferrous min. 20mm dia. Accessory M500 TG Target Disc Available.

Start up Delay ——— User Selectable 0-30 Seconds

Calibration ——— Unit is automatically calibrated by the application of a magnet. (Applied to CAL point on label when shaft is running at speed).

Repeat Accuracy — Better than 2%

Enclosure ————— Moulded PC/ABS.

Protection ——— IP67 dust & water tight.

Trip Point ——— Using Single Set Point either 10% or 20% underspeed. Using Dual Set Points both 10% and 20% underspeed.

Output Relay ——— First Relay Normally Open. Contact Closes at 10% speed. Second Relay Normally Closed. Opens at -20% speed. Rated 2.5A 240V AC.

LED Display ——— RED LED indicates input pulses. GREEN LED shows output at nominal speed and acts as calibration aid. It may flicker during normal operation.

Weight ————— 185 grams.

Tacho Output ——— Opto-isolated output provided, rated at 30V dc 100mA max, fully protected. To feed tachos and other electronic equipment.

GUARANTEE

The equipment is covered by a 12 months guarantee from the date of shipment. Any faults arising due to faulty materials or workmanship, within the guarantee period, will be corrected free of charge providing the equipment is returned to us carriage paid.



**BRAIME ELEVATOR
COMPONENTS LTD.**
Hunslet Road, Leeds,
England. LS10 1JZ
Tel: +44 (0) 113 246 1800
Fax: +44 (0) 113 243 5021
e-mail: elevators@braime.com
Web: www.braime.com



**4B ELEVATOR
COMPONENTS LTD.**
729 Sabrina Drive, East Peoria
Illinois 61611-3578
Telephone: 309-698-5611
Fax: 309-698-5615
e-mail: 4b@go4b.com
Web: www.go4b.com



SETEM
2 Route de Corbie
80800 Lamotte Warfusée
France
Telephone: 03 22 42 32 26
Fax: 03 22 42 37 33
e-mail: setem@setem.fr
Web: www.braime.com/setem

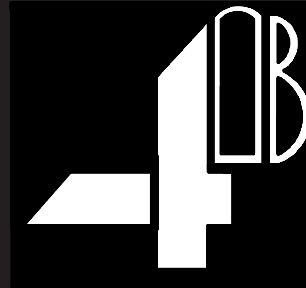

SPEEDSWITCH M800 UNDERSPEED MONITOR

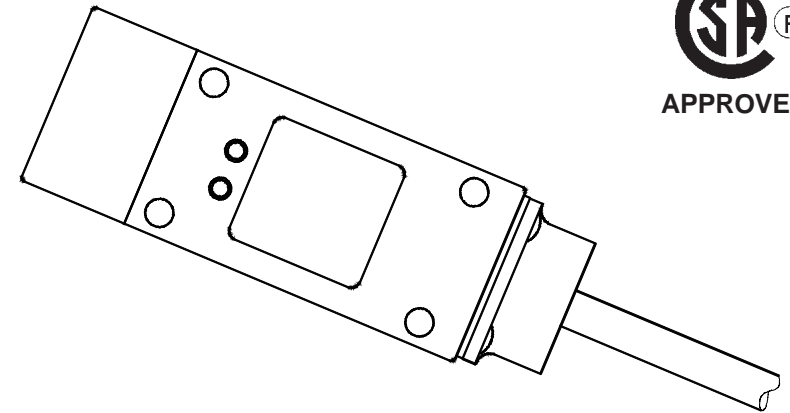

WARNING:

O.S.H.A. requires that all exposed rotating shafts are provided with a full guard. Therefore, this device and its target must be equipped with a guard.

INSTALLATION INSTRUCTIONS

TECHNICAL INFORMATION

**UNDERSPEED MONITOR - PART Nos. 220V ac M8001V2FC
110V ac M8001V1FC
24V dc M8001V4FC**

GENERAL

The M800 motion monitor detects slip, low or zero speed on belt and bucket elevator legs, conveyors or rotating machinery.

The unit requires no contact with the shaft, is fully solid state, and has a virtually unlimited operating life. The M800 may be used either as a dual trip unit giving an alarm at 10% below set speed and a shutdown signal at 20% below set speed, or a single trip giving a shutdown signal at 20%. With the addition of an auxiliary relay, it can also give a shut down signal at 10% (see fig. 4).

An automatic calibration facility allows the unit to be programmed to give a start up delay of up to 30 seconds, whilst simultaneously calibrating for nominal speed.

An auxiliary pulse output is provided to feed suitable speed indicators.

INSTALLATION

The inductive sensing device, located in the front of the M800 enclosure is designed to detect a metal target on a shaft. The target can be a bolt head or similar.

Ideally, the target should be a ferrous metal but non-ferrous metal will detect at a shorter range. Maximum range for a ferrous material is 11/32" (9mm) and for non-ferrous metal is 7/32" (6mm), assuming a 3/4" (19mm) diameter target. Smaller targets may be used but operating distance will be reduced.

The M800 should be mounted adjacent to the target, ensuring that the distance to the target does not exceed the stated maximum. Typical mounting methods are shown in fig 1.

When mounted against a solid steel shaft, the target or bolt head should protrude from the shaft about 3/8" (10mm). Otherwise the sensor will not be able to separate the target from the shaft and the red input light would stay on permanently (instead of flickering) and it would not be possible to calibrate the unit.

TACHO OUTPUT

An opto-isolated output is provided, rated at 30V 100mA max. The output is on when the target is detected and off otherwise. This output pulse can be used to feed remote tachos or other electronic products.

Mounting Procedure For Speedswitch M800 Motion Monitor

Fasten the Speedswitch to a suitable mounting bracket, with the nose of the switch within the sensing range of the target., as shown below, and then wire up and calibrate as described in Set-up procedure.

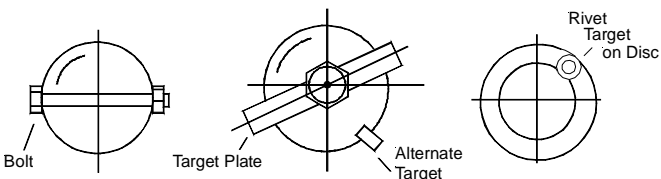
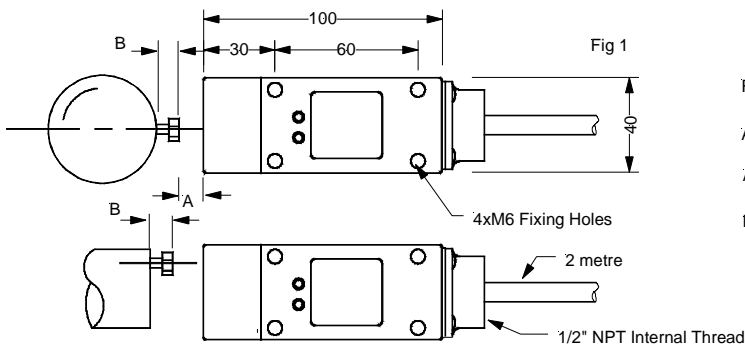

RANGE FOR SETTING UP

A = 9mm max for ferrous target

A = 6mm for non ferrous target

B = 10mm minimum

Examples of Targets

WIRING

The unit connections and typical wiring diagrams are given in figs. 2,3 4 and 5. Note that contacts are voltage free and there is no connection between terminal 1 and the relay, until links are installed as required. See figs. 2,3 and 4. Note that the startup is initiated by applying power

COMMISSIONING & AUTO-CALIBRATION

The M800 is factory calibrated at a set speed of 10 ppm and a start up delay of 5 seconds. For applications requiring a different speed or delay, see initial Setting up Operation. For future re-calibration see Re-Calibration for a Different Setting.

INITIAL CALIBRATION

If the start up delay required is less than 5 seconds (if longer, see re-calibration below).

- 1) Ensure that all connections are correct.
- 2) Apply power to the M800 and start machinery.
- 3) Allow the machine to reach nominal speed and then hold either end of the magnet (supplied) on the CAL point on the label for the start up delay required then remove the magnet. The delay can be set by counting flashes on the output LED while the magnet is on the CAL point. Each flash represents 1 second.
- 4) The output LED will flash to 'echo' back the set time and will automatically calibrate to 10% and 20% below speed.

RE-CALIBRATION FOR A DIFFERENT SETTING

If the unit is to be calibrated to a higher speed and shorter time delay, follow the initial procedure detailed above. If the speed is lower or the required delay longer, the M800 may cut out before the machine has reached speed, in this case follow the procedure below:-

- 5) Hold one end of the magnet on the CAL point.
- 6) Switch on the M800 and machinery.
- 7) Allow the machinery to reach speed and remove the magnet.
- 8) Wait until the output light stops flashing and then calibrate as detailed under Initial Calibration 3&4.

Connections

