

## M300 Slipswitch

### Detect Dangerous Underspeed Slow Down Conditions

#### APPLICATION

The M300 Slipswitch is a simple inductive shaft speed monitoring device. The self-contained unit has a single set point, which signals when the shaft speed has dropped by 20% of normal running speed. It is used for detecting dangerous slow downs and underspeeds on conveyors, bucket elevators, airlocks, mixers, fans, grinders and many other machines.

#### METHOD OF OPERATION

An inductive sensing device located in the nose of the M300 enclosure will detect a metal target. This target can be an existing bolt head or device attached to a shaft. During installation the M300 is set to the normal machine shaft RPM by calibrating with the magnet provided. The internal microprocessor sets the underspeed output to operate at exactly 20% below normal machine shaft RPM, so users are able to use the M300 output for automatic shutdown during a dangerous underspeed or belt slip condition.

#### FEATURES

- ▶ Underspeed Detection at 20%
- ▶ Adjustable start-up delay - 0 to 60 seconds
- ▶ Magnetic Calibration of Microprocessor
  - start-up delay
  - normal running speed
- ▶ Universal voltage: 24-240 VAC/12-240VDC
- ▶ Microprocessor Accuracy
- ▶ LED Indication
- ▶ Certified to ATEX & IECEx Zone 20 & CSA Class 2 Division 1 Groups E, F & G
- ▶ IP67 Protection: Totally Sealed Construction

#### PART NUMBERS/ACCESSORIES

- ▶ M3001V10AI Slipswitch M300 2-Wire
- ▶ M3005V10AI Slipswitch M300 5-Wire
- ▶ WG1-8A-BR Whirligig (target/bracket/guard)
- ▶ MAG2000M Mag-Con Magnetic Connector for Whirligig

Detailed specifications, wiring diagrams and installation / operating instructions available immediately upon request.



M3001V10AI & M3005V10AI



**ATEX-Approved**  
Ex II 1D T100°C-IP 65-ZONE 20

**IECEX**



**CLASS 2 Div. 1**  
Groups E, F & G

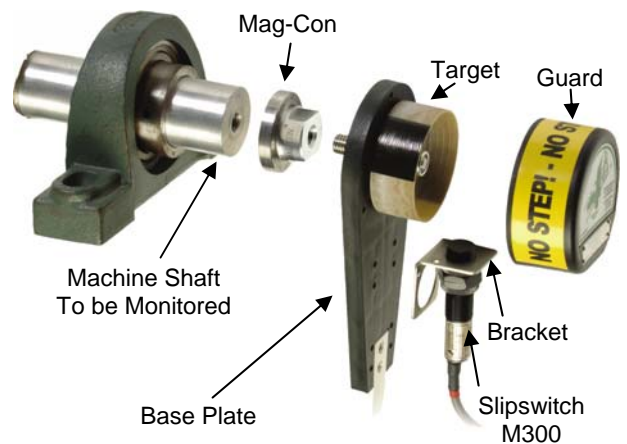

**Slipswitch M300 shown with optional Whirligig and Mag-Con**

(Used for simple and reliable installation on shaft speed monitoring applications)

Please refer to instruction manual for correct installation .  
Information subject to change or correction. May 2007.

## M300 Dimensions

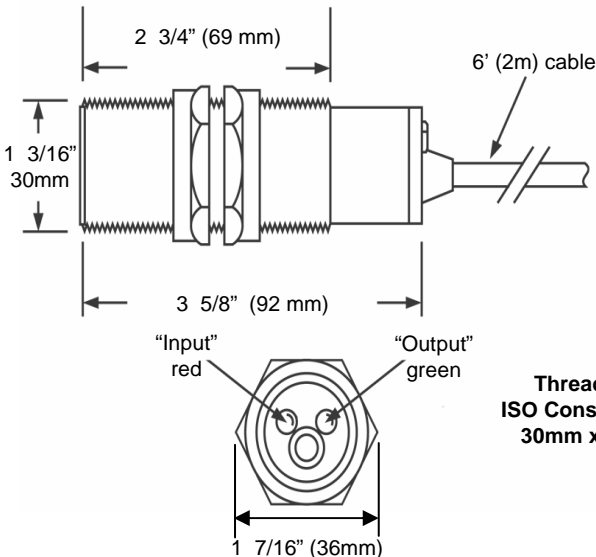

## M300 Connections

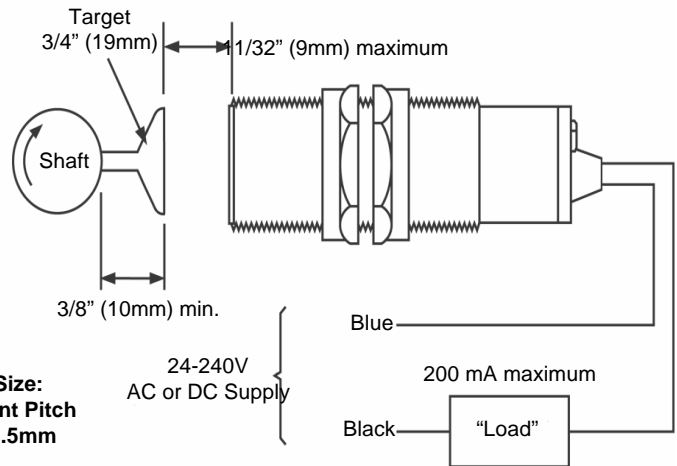

Note: The "Load" must have the same voltage rating as the supply being used.

## TECHNICAL SPECIFICATIONS

### Slipswitch – Detect Dangerous Underspeed Conditions

	M3001V10AI - (M300 2-Wire)	M3005V10AI - (M300 5-Wire)
<b>Power Supply:</b>	24-240 VAC/DC	12-240 VDC / 24-240 VAC
<b>Power Consumption:</b>	30 mA	30 mA
<b>Fuse:</b>	5 amp maximum	5 amp maximum
<b>Output:</b>	Triac, normally closed above set speed Normally open at 20% below set speed	Relay, normally closed above set speed Normally open at 20% below set speed
<b>Switching Capacity:</b>	200 mA maximum	N/A
<b>Contact Rating:</b>	N/A	3A – 240 VAC
<b>Saturation Voltage:</b>	8 Volts maximum (output on)	N/A
<b>Leakage Current:</b>	1.6 mA maximum (output off)	N/A
<b>Operating Temperature:</b>	-13°F (-25° C) to +158°F (70° C)	-13°F (-25° C) to +158°F (70° C)
<b>Start Up Delay:</b>	0-30 seconds (programmable)	0-30 seconds (programmable)
<b>Sensing Range:</b>	11/32" (9mm) maximum on ferrous metal	9mm maximum on ferrous metal
<b>Input Pulse Range:</b>	10-3600 ppm maximum	10-3600 ppm maximum
<b>Trip Point:</b>	20% below set speed	20% below set speed
<b>LED Indicator:</b>	Red - "target sensed" Green - "set speed"	Red - "target sensed" Green - "set speed"
<b>Relative Humidity:</b>	90% RH	90% RH
<b>Calibration:</b>	Magnetic	Magnetic
<b>Cable:</b>	6' (2m) 2 conductor	2 m
<b>Approval:</b>	Class 2 Div. 1 Groups E, F, & G (US and Canada)	ATEX & IECEx Zone 20, CSA
<b>Protection:</b>	IP67	IP67

Please refer to instruction manual for correct installation .  
Information subject to change or correction. May 2007.