

ADJUSTABLE LEVEL KIT FOR BINSWITCH DE 0,65 A 2,05 METRES

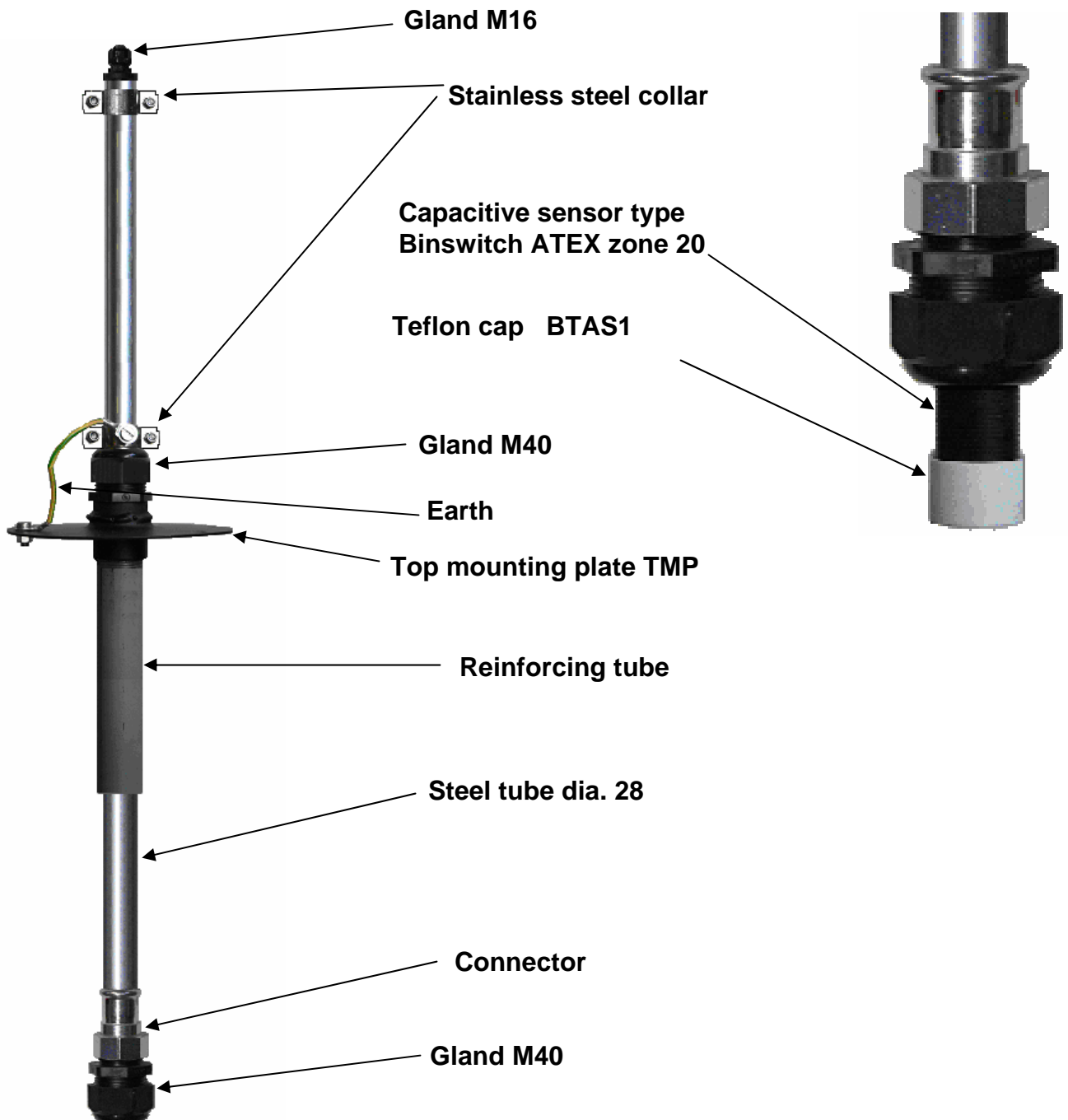

* Delivered without Binswitch and BTAS1

Detailed specification, wiring diagrams and installation/operating instructions available immediately upon request.

Please refer to instruction manual for correct installation .
Information subject to change or correction. July 2007.

Low level

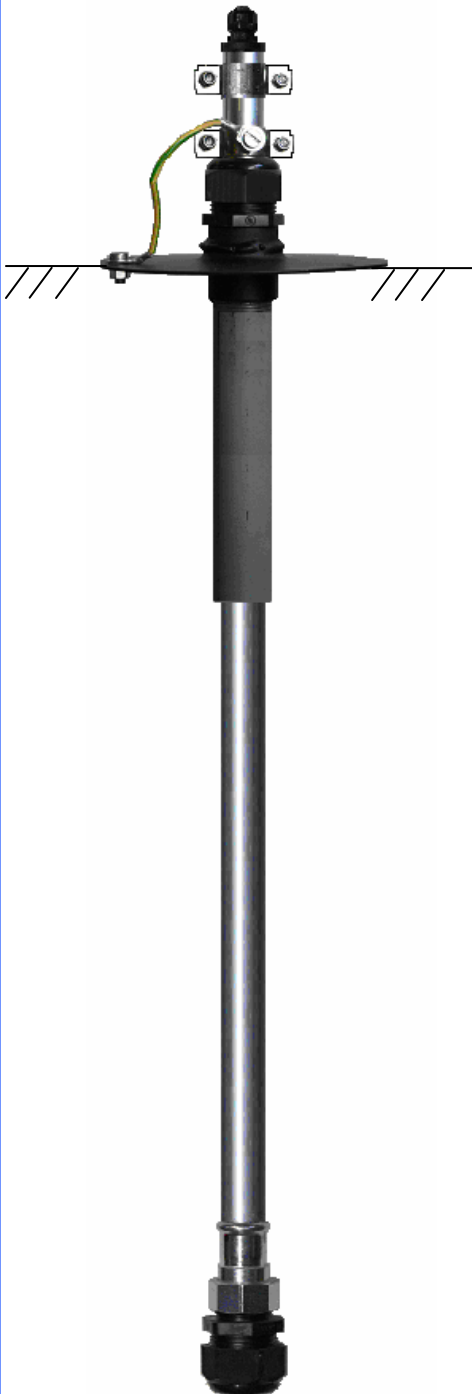

Medium level

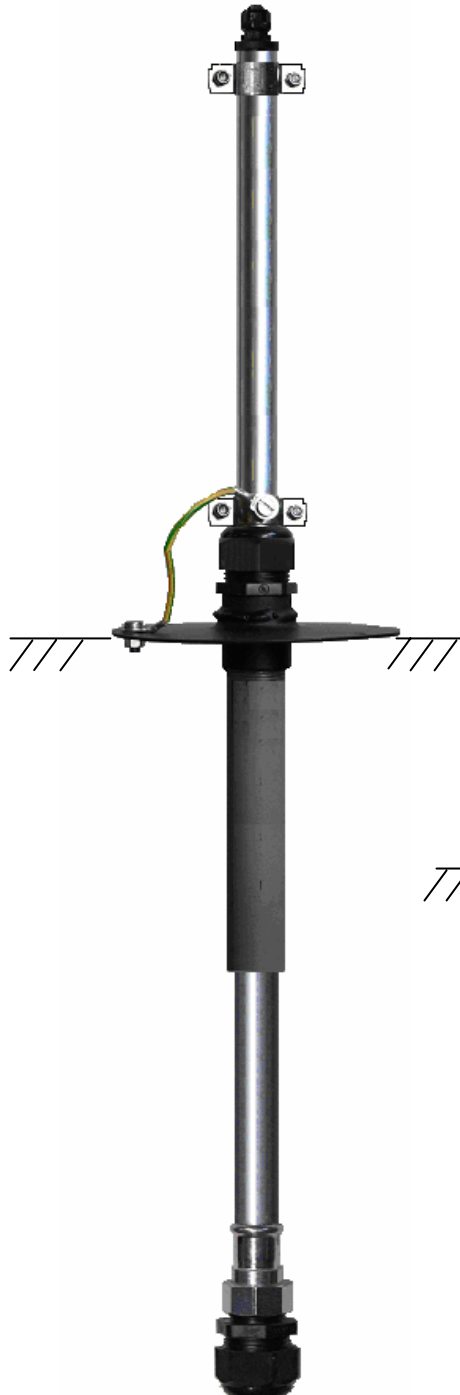

High level

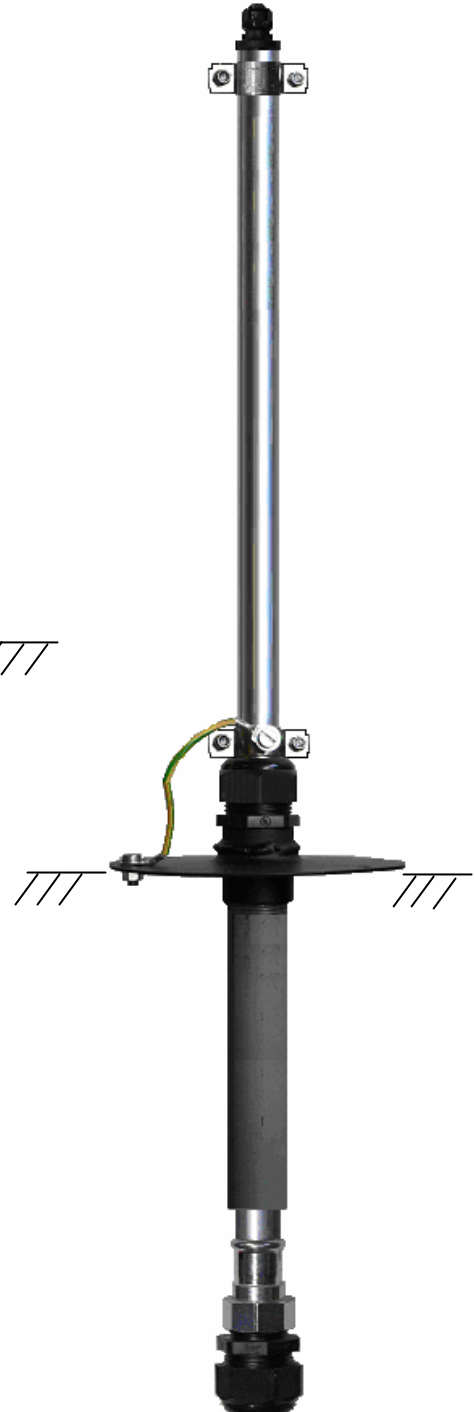

Please refer to instruction manual for correct installation .
Information subject to change or correction. July 2007.