



F500 Elite.

FIELDBUS ADAPTER.

**Watchdog Elite to Profibus DP slave
communications.**

(Software Version 4.0.1)

CONTENTS

INTRODUCTION

- 1 SPECIFICATIONS
- 2 INSTALLATION INSTRUCTIONS
- 3 ELECTRICAL WIRING
- 4 OPERATING INSTRUCTIONS

FAULT FINDING

CONTACT INFORMATION

DRAWINGS

- A CONNECTING THE F500 ELITE TO AN AC SUPPLY
- B CONNECTING THE F500 ELITE TO A DC SUPPLY
- C F500 ELITE TO WATCHDOG ELITE CONNECTIONS
- D F500 ELITE TO VT100 SERIAL TERMINAL CONNECTIONS
- E GENERAL CONNECTION DETAIL

APENDIX A

The Profibus GSD file

NOTE: This interface may take as long as 20 seconds to correctly initialize. Do not attempt communications before that time.

F500 FIELDBUS ADAPTER.

INTRODUCTION

This version of the F500 Elite Fieldbus adapter had been designed to work as a Watchdog Elite communications gateway and has been designed specifically to allow up to 32 Watchdog control units to be networked together through their own built in communications system. The network data can then be passed through the Fieldbus adapter to a Profibus DP network. The communications control unit is housed in a self-contained wall-mounting enclosure, and will operate from 115v to 230v AC or from 12v to 24v DC.

1. SPECIFICATIONS

1.1 The Control Unit

A plastic enclosure houses the electronics and terminal connectors. The unit contains a printed circuit board to accommodate power supply circuitry, microprocessor, Fieldbus card and terminals. The design is capable of accommodating 8 of the most common Fieldbus interfaces.

Electrical Supply	-	115 to 230VAC +/- 10% 50/60Hz
	-	12 to 24VDC +/- 10%
Power Consumption	-	10VA/10 WATTS
Terminals	-	Power 4mm ² 14 AWG max
	-	Communications, as appropriate to the Fieldbus module.
Protection	-	NEMA12, IP55
Height	-	9.7", 246mm
Width	-	7.4", 188mm
Depth	-	4", 102mm
Fixing Centres	-	8.75" high x 4" wide, 222mm x 102mm
Cable Entry	-	2 Holes 11/8" DIA, 28mm, 3/4" CONDUIT
Weight	-	3lbs, 1.3Kg

2. INSTALLATION INSTRUCTIONS

The Control Unit

The Control Unit box should be installed in a suitable control or starter switch room. The box should have sufficient space to open the lid for wiring.



The Control Unit is susceptible to static voltage. Connection of a clean ground to terminal 29 is essential for optimum performance. Prior to this connection, static handling precautions should be taken.

3 ELECTRICAL WIRING

Refer to Drawings A, B, C & E

When installing the equipment in an area which is likely to be hazardous from Ignitable Dusts, use liquid tight conduit and fittings and follow all local codes.

4 OPERATING INSTRUCTIONS

The Fieldbus Adapter is a self contained unit and there are no user configurable options with the exception of the ProfiBus slave address. The adapter is equipped with three communications ports; RS232, RS485 and Profibus DP (slave).

The RS232 is a simple interface which can be used for diagnostics purposes. The data from this port is formatted to work with a VT100 display terminal. Any terminal or terminal emulator capable of supporting the VT series or compatible commands can be used with this port although the data has been optimised to work with VT100. The RS232 port operates at a fixed data rate of 9600, N, 8, 1.

The RS485 port is a four wire, twin twisted pair full duplex serial port and has been specifically configured to work with the Watchdog communications network. You should not connect any other devices to this port unless you wish to monitor the Watchdog data directly. If this is the case then contact your supplier for details relating to the Watchdog command protocol.

The Profibus interface provides the following:

Transmission media: Profibus bus line, type A or B specified in EN50170

Topology: Slave configuration

Fieldbus Connector: 9 pin female DSUB

Cable: shielded copper; twisted pair

Optically isolated bus A and B termination

Address range 1-99 selected by on board switch

Maximum cyclic I/O data size of 244 bytes

Optional bus termination, switch selectable

Led status indication

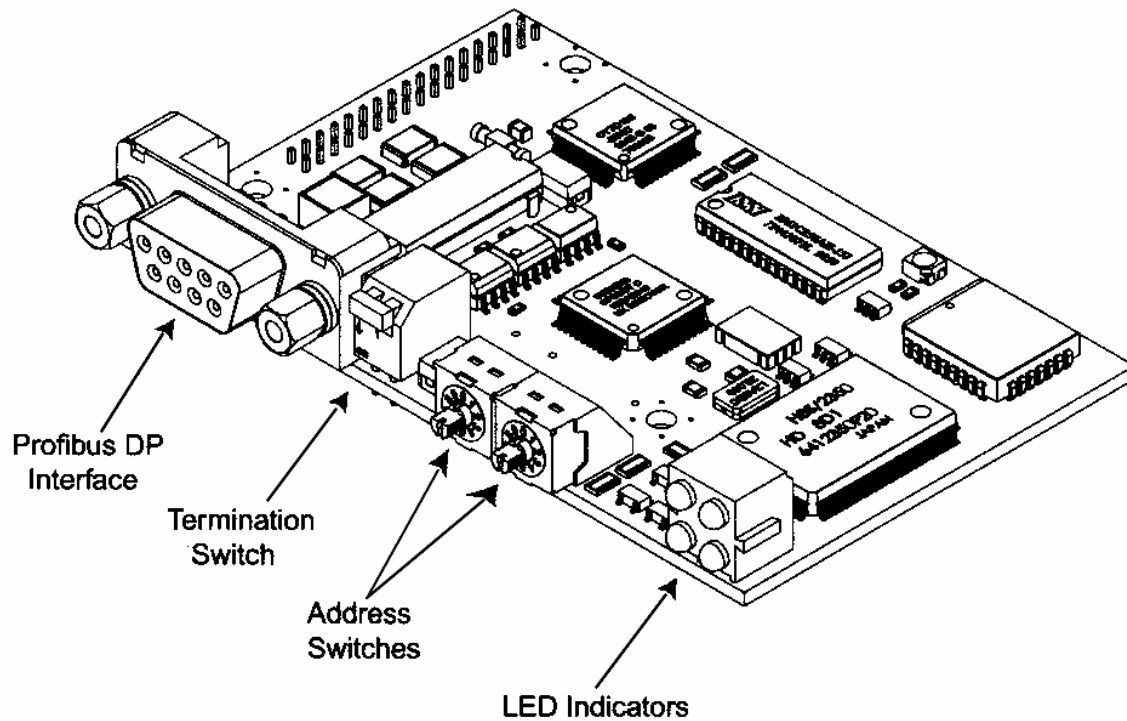

The above diagram shows the location of the main parts of the Profibus module.

The address switches allow the unit slave address to be set between 01 and 99. The left hand switch sets the ten's digit of the address and the right hand switch sets the unit digit of the address. If you decide to change the address then you must reset the interface by first removing and then reconnecting power. The default unit address is 77.

The termination switch can be used to add termination resistors to the Profibus interface if required. If the F500 Profibus interface card is the first or last module on the Profibus network, then the switch needs to be set to ON else it must be set to OFF.

The Profibus connections are shown below and are identical to the standard Profibus DSUB connections.

Pin	Signal	Description.
1	N/C	No connection
2	N/C	No connection
3	B line	Positive RxD/TxD according to RS485 specification
4	RTS	Request to send
5	GND BUS	Isolated ground connection
6	+5V BUS	Isolated +5V connection
7	N/C	No Connection
8	A line	Negative RxD/TxD according to RS485 specification
9	N/C	No Connection

The status LED's are grouped in a single block of four and indicate the following status.

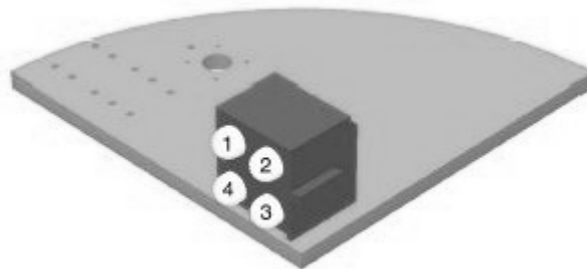

Led 1 Status

<i>Colour</i>	<i>Frequency</i>	<i>Description</i>
-	-	Not Used

Led 2 Status

<i>Colour</i>	<i>Frequency</i>	<i>Description</i>
Green	Solid on	Module is ON-LINE and data exchange is possible

Led 3 Status

<i>Colour</i>	<i>Frequency</i>	<i>Description</i>
Red	Solid on	Module is OFF-LINE and data exchange is not possible.

Led 4 Status

<i>Colour</i>	<i>Frequency</i>	<i>Description</i>
Red	1 Hz	Interface board initialisation failure
Red	2 Hz	Network configuration does not match module configuration
Red	4 Hz	Initialisation failure of the Profibus interface IC

Input register data map (Cyclic I/O data transfer – Max 244 bytes see page 18).

The Watchdog data is automatically read for up to 32 controllers. The data returned is processed and stored in the following format. The position of the data is fixed within the input data table.

Watchdog Address	Input Bytes	Watchdog Address	Input Bytes	Watchdog Address	Input Bytes	Watchdog Address	Input Bytes
1	3&4 + 5&6	9	35-38	17	67-70	25	99-102
2	7-10	10	39-42	18	71-74	26	103-106
3	11-14	11	43-46	19	75-78	27	107-110
4	15-18	12	47-50	20	79-82	28	111-114
5	19-22	13	51-54	21	83-86	29	115-118
6	23-26	14	55-58	22	87-90	30	119-122
7	27-30	15	59-62	23	91-94	31	123-126
8	31-34	16	63-66	24	95-98	32	127-130

Byte 1 is used to indicate the number of Watchdogs that are responding to the request for data. Byte 2 is unused. The remaining data stored in the input bytes is constructed as follows.

The data from each Watchdog is stored in 4 consecutive bytes of data.

The first two bytes of the group of 4 (e.g. 3 & 4) represent the Watchdog speed.

The second two bytes of the group of 4 (e.g. 5 & 6) represent the Watchdog status.

The Watchdog speed is encoded in the following manner.

Four hexadecimal digits are used to represent the measured speed for the Watchdog. The rightmost three and a half are the main body of the speed and the upper half of the fourth is the position of the decimal place within the information. If the most significant two bits are '00' then decoding of the speed is not required. If the two bits are '01', then the resulting value should be divided by 10 and if the two bits are '10' then the speed should be divided by 100. The top two bits should never be '11' as this has no meaning.

Bit 7	Bit 6	Description (e.g. most significant bits of the first speed byte 3)
0	0	Bits 5-0 of the first byte and the whole second represent the speed.
0	1	Same as above but the speed and should be divided by 10
1	0	Same as above but the speed and should be divided by 100
1	1	Not used.

An example of this can be seen below.

Watchdog speed = 6E (e.g. byte 3) & 1E (e.g. byte 4). The leftmost digit (6) = '0110' in binary which can be separated into '01' (bits 7 and 6) for speed scaling and '10' (bits 5 and 4) for the upper speed digit. If you strip off bits 7 and 6 you are left with a decoded value of 2E & 1E for the speed and '01' or divide by 10 for the scaling. The speed 2E1E converted to decimal = 11806 and then divided by 10 results in an actual speed of 1180.6. By default the Watchdog will display speed in pulses per minute but it can be scaled to display any value required, refer to the Watchdog manual for further detail.

The Watchdog status is encoded as described in the following manner.
 Two data bytes are used to represent the status for the Watchdog. The first status byte (e.g. **byte 5**) is the status code and the second byte (e.g. **byte 6**) represents any data which is associated with the status code.

Status Code (First status byte)	Status Data (Second status byte)	What it means.
09	% Complete	Watchdog is calibrating (% complete).
0F	-	Elevator is stopped due to persistent belt slip.
10	-	Elevator is stopped due to persistent over calibration.
11	-	Misalignment detected on Top & Bottom sensors.
22	-	Elevator is stopped and is ready to run (Normal stop condition)
23	Start-up Delay In seconds	Elevator is accelerating. (xx seconds remain)
24	Speed %	Elevator running within programmed limits.
25	Speed %	Stop relay has been de-energised (Fault stop condition)
27	Time to alarm In seconds	Misalignment detected. (xx seconds to alarm)
2A	Time to alarm In seconds	Over speeding: Alarm relay about to de-energise (xx seconds to alarm)
2D	-	Misalignment detected at the top of the elevator.
2F	Time to stop In seconds	Over speeding: Stop relay about to de-energise (xx seconds to stop)
31	-	Speed display is over range: check the scaling factor.
32	-	Start elevator to commence calibration procedure.
36	1-4	Watchdog has detected an internal fault.
39	Time to alarm In seconds	Belt slipping. (xx seconds to alarm)
3A	Time to stop In seconds	Belt slipping: Stop relay about to de-energise. (xx seconds to stop)
3B	-	Elevator stopped due to lack of acceleration.
3C	Time to stop In seconds	Persistent alarm. (xx seconds to alarm)
3D	-	Elevator stopped: Speed has exceeded over speed limit.
3E	-	Interlock signal off, waiting for zero speed.
3F	-	Elevator stopped: Persistent alarm condition.
40	-	Elevator stopped: Severe under speed.
41	-	Watchdog is not calibrated: Please see the manual.
42	-	Misalignment detected at the bottom of the elevator.
44	-	Wrong access code used when changing setup.
46	Speed %	Elevator speed less than alarm level (slipping)
47	Speed %	Elevator speed more than alarm level (Over speeding)
49	-	Suspected open circuit or faulty bearing temperature sensor.

4A	-	Suspected fault on one or more MAS. Could be mains pickup.
4E	-	Plug switch is open.
50	Temperature In °C	Hot bearing at zone 1. The temperature will only be displayed when NTC sensors are used.
51	Temperature In °C	Hot bearing at zone 2. The temperature will only be displayed when NTC sensors are used.
52	Temperature In °C	Hot bearing at zone 3. The temperature will only be displayed when NTC sensors are used.
53	Temperature In °C	Hot bearing at zone 4. The temperature will only be displayed when NTC sensors are used.
54	Temperature In °C	Hot bearing at zone 5. The temperature will only be displayed when NTC sensors are used.
55	Temperature In °C	Hot bearing at zone 6. The temperature will only be displayed when NTC sensors are used.
56	-	HBS is open circuit at zone 1
57	-	HBS is open circuit at zone 2
58	-	HBS is open circuit at zone 3
59	-	HBS is open circuit at zone 4
5A	-	HBS is open circuit at zone 5
5B	-	HBS is open circuit at zone 6

An example of the status code might be '2463'. The first status byte (byte 5) '24' show that the equipment is running within the specified alarm limits and the second status byte (byte 6) '63' indicate that the speed is 99% if it's calibrated value. Where a value is not shown or a '-' is used in the table, this indicates that any data present in this field should be ignored.

Several different conditions may occur at the same time whilst the Watchdog is operating. If the Watchdog is running within calibrated range but also detects a motion sensor fault then the information returned may look something like this.

'2463' Running at 99% of calibrated speed.

Followed three seconds later by

2D--' Misalignment detected at the top of the elevator.

Followed three seconds later by

'3CAA' Persistent alarm, 170 seconds to go.

The messages would then repeat with any new values in the status data field.

Due to some limitations in the speeds involved in updating the Watchdog information, rapid changed of data could be missed or be present for only a very short period of time.

If the Watchdog is placed in one of the two test modes, the messages below will be returned in the following order.

First two bytes	Second two bytes	The first two bytes show the speed data and the second two bytes show the status and status data.
xx & xx	06 & xx	Over speed Stop as a percentage of calibrated speed.
xx & xx	05 & xx	Over speed Alarm as a percentage of calibrated speed.
xx & xx	02 & xx	The actual calibrated speed
xx & xx	03 & xx	Under speed Alarm as a percentage of calibrated speed.
xx & xx	04 & xx	Under speed Stop as a percentage of calibrated speed.
----	07 & --	Performing internal test.
----	4C & --	Testing the Alarm relay.
----	4D & --	Testing the Stop relay.

Codes 4C and 4D are only returned if the extended test is in operation.

Diagnostics Display.

The F500 Elite is equipped with a simple RS232 serial interface. This interface can be used to monitor the communications with the Watchdog Elite. The information displayed contains diagnostic data about the Fieldbus module and the speed and status of each Watchdog. A VT100 or compatible display terminal should be used to display the information.

```

F500 Elite Communications Gateway. (WatchDog)
Elite Software Version - 4.0.1
CBU Version= 1.00
API Version= 2.16
FBI Version= 1.17
ABI Version= 1.32
FieldBus Type = Profibus-DP
S2468E

WDOG: SPEED: STATUS: WDOG: SPEED: STATUS: WDOG: SPEED: STATUS: WDOG: SPEED: STATUS
01 0000 4100 09 .....
02 ..... 10 .....
03 ..... 11 .....
04 ..... 12 .....
05 0000 3200 13 .....
06 ..... 14 .....
07 ..... 15 .....
08 ..... 16 .....
17 ..... 25 .....
18 ..... 26 .....
19 ..... 27 .....
20 ..... 28 .....
21 ..... 29 .....
22 ..... 30 .....
23 ..... 31 .....
24 ..... 32 .....

Total Watchdogs Found = 2

```

Above is an *example* screen image from the diagnostics display. The information displayed will vary slightly dependent upon the fieldbus interface used.

CBU Version = X.XX – This is the control base unit software version.
API Version = X.XX – This is the application interface software version.
FBI Version = X.XX – This is the Fieldbus interface software version.
ABI Version = X.XX – This is the AnyBus interface software version.

Fieldbus type = Profibus DP – This describes the type of Fieldbus module which is installed in the F500 Elite. If the Fieldbus module is faulty some or all of this data will change to suggest which area may be at fault. For example, FBI version number might become 245.55. An unusually large number such as this is not usually associated with a normally functioning module and would suggest that the Fieldbus interface controller has failed. In the event of this or any other fault, contact your supplier.

The sequence S2468E indicated that the system has initialised correctly, a deviation from this indicates that one or more parts of the initialisation process has failed. If this is the case, recycle power and see if this clears the problem. If you still have problems with the initialisation of the unit contact your supplier and tell them what you see on the diagnostics display. The main area of the display shows the speed and status of each Watchdog Elite as described on pages 8, 9 and 10 of this manual.

Diagnostics LED.

Located on the main circuit board, just above the RS485 connections to the Watchdog you will find an LED indicator (usually RED). This indicator will flash every time the F500 attempts to communicate with the Watchdogs. The LED will normally flash at a consistent rate followed by a very short pause. The short pause indicates that the F500 is updating the information which it stores internally. A significant deviation from this sequence is an indication that there is a problem. If this happens, contact your supplier for further information.

CHECK LIST
For problems after initial start-up

1. Is there excessive interference on the electrical power supply? Power conditioners and surge (spike) suppressor may have to be fitted.
2. Has the wiring for the Watchdog and Fieldbus been routed away from power cables?
3. Is the F500 Elite circuit properly grounded?
4. Is the Micro-processor control unit overheating, if so mount in temperature-controlled environment of maximum temperature 104°F (40°C).
5. Check that high powered 'Walkie Talkie' radios are not operated immediately near the control unit or Watchdogs as this will affect the performance.
6. Check that the communications/power cable is connected correctly and in accordance with DRG A, B, C and E.
7. Check that there is no exception status reported.
8. If only part of the diagnostics data is displayed on the terminal screen then turn the F500 Elite off then back on again without removing power to the display terminal.
9. If the Watchdogs are not responding or are intermittent, check that the termination resistors are correctly fitted.

CONTACT INFORMATION

**BRAIME ELEVATOR COMPONENTS LIMITED
HUNSLET ROAD ♦ LEEDS LS10 1JZ ♦ ENGLAND
Tel. +44 (0) 113 246 1800 ♦ Fax. +44 (0) 113 243 5021**

**4B COMPONENTS LTD
729 SABRINA DRIVE ♦ EAST PEORIA, IL 61611-3578 ♦ USA
Tel. 309 698 5611 ♦ Fax. 309 698 5615**

**SETEM
9 ROUTE DE CORBIE ♦ 80800 LAMOTTE WARFUSEE ♦ FRANCE
Tel. (33) 03 22 42 32 26 ♦ Fax. (33) 03 22 42 37 33**

**4B SUDAMERICA S.A.
ARCOS 2967 ♦ 1429 BUENOS AIRES ♦ ARGENTINA
Tel. (54) 114 702 2364 ♦ Fax. (54) 114 701 5075**

**Web: <http://www.go4b.com>
Email: go4b@aol.com**

Connecting the F500 to an AC supply

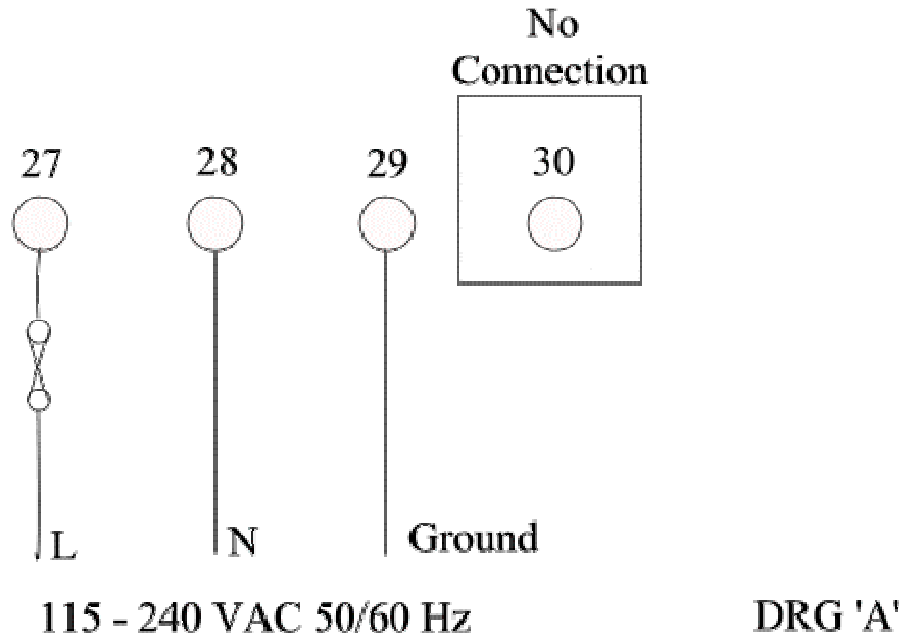

Connecting the F500 to a DC supply

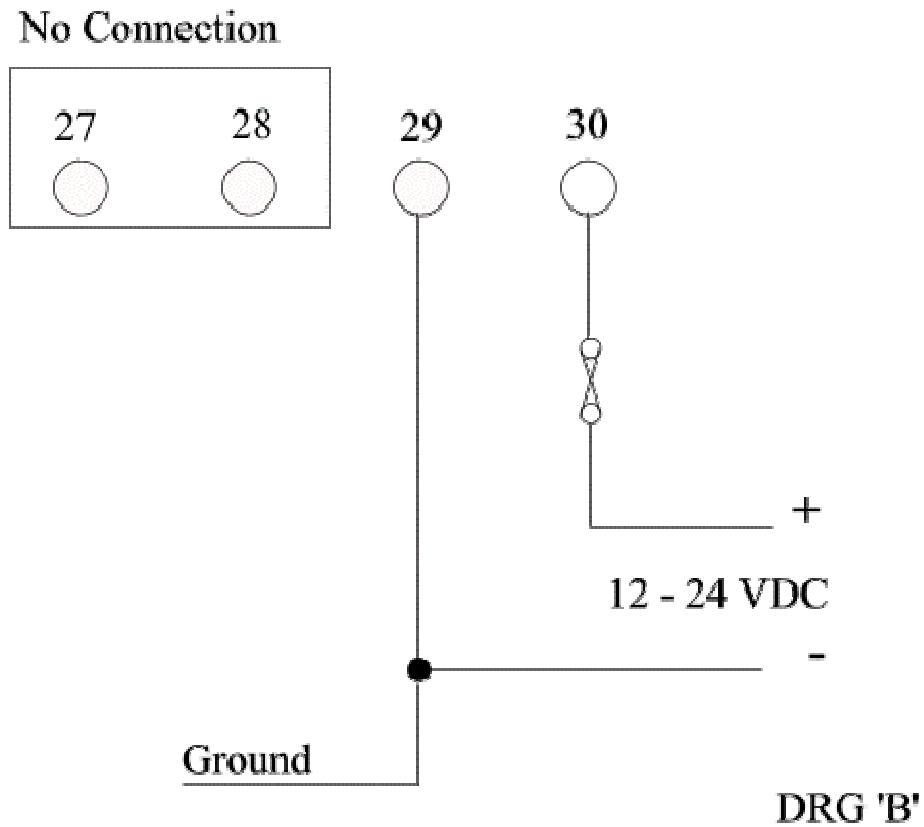

F500 elite to Watchdog connections

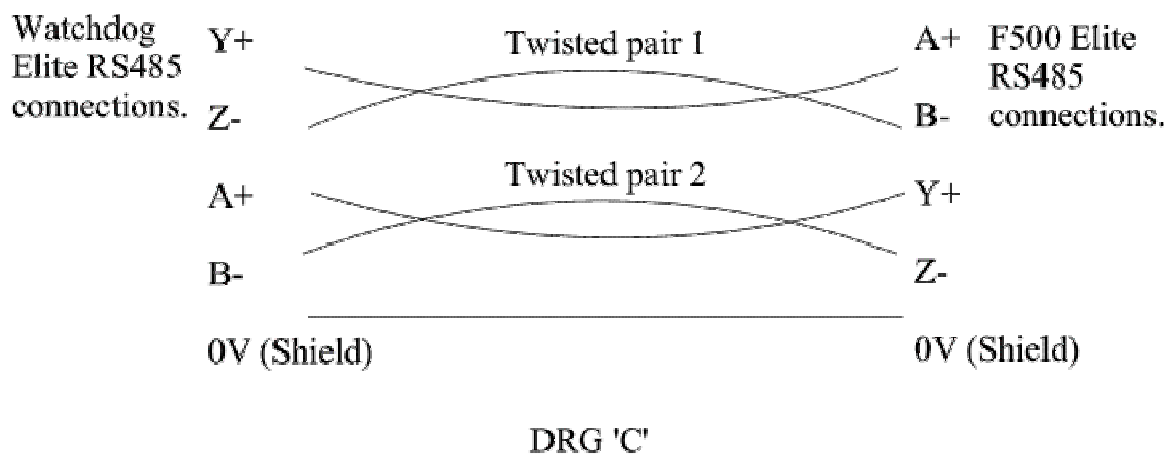
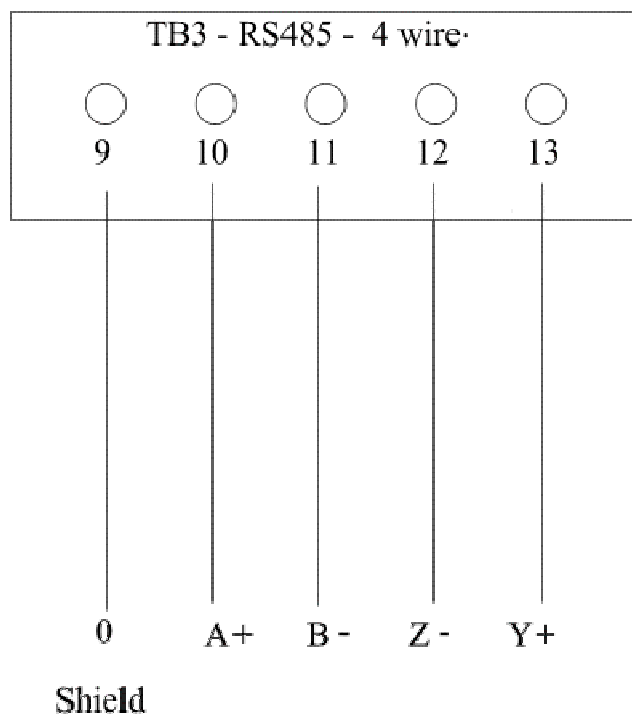

F500 elite to VT100 terminal connections.

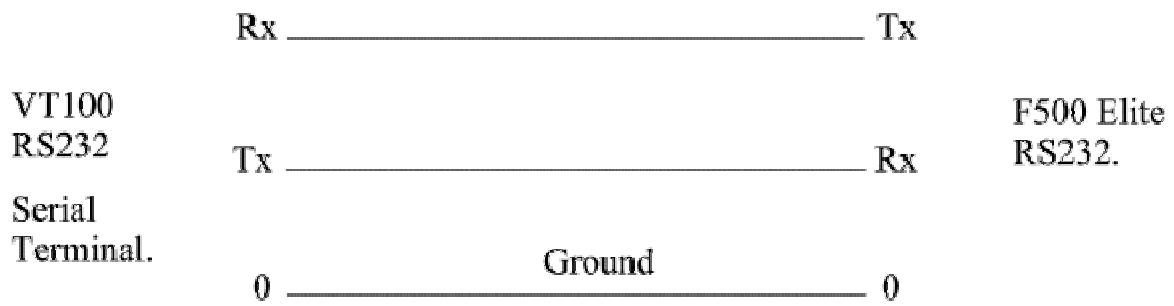
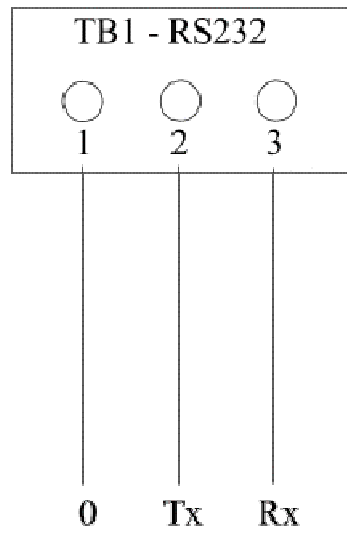

DRG 'D'

General connection detail for the Watchdog to an F500 elite.

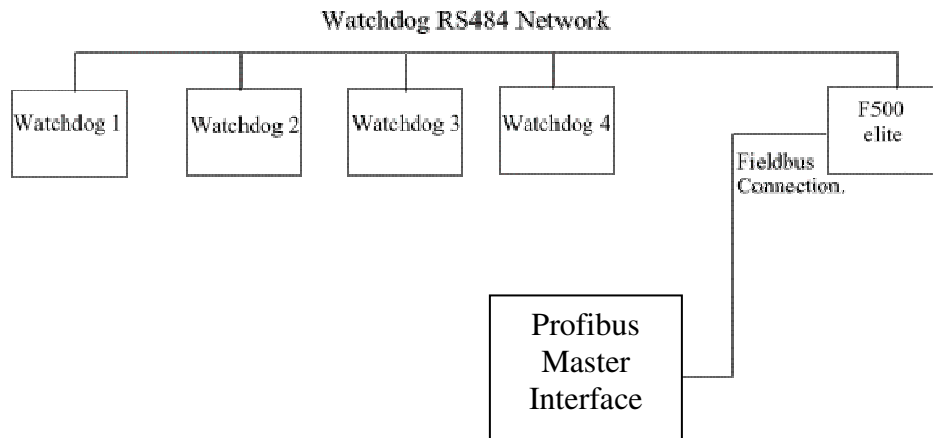
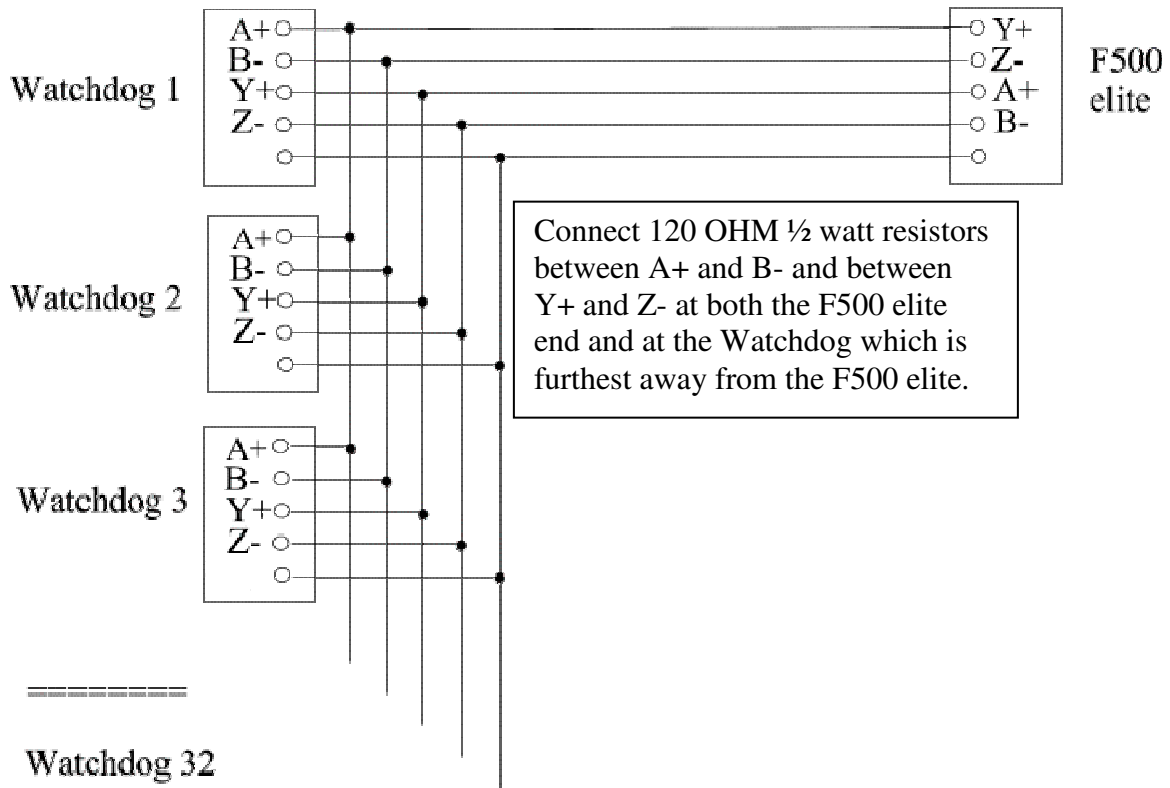

DRG 'E'

APPENDIX 'A'

Master/Slave configuration.

The F500 when equipped with a Profibus interface is supplied with a GSD file on CD to aid with initial configuration if required. Should this file become corrupt or is lost then the following information can be used to recreate the file. The F500 does not require the use of the GSD file in order to operate correctly and this is only provided as a courtesy to the user. If you monitor 32 Watchdogs the interface will require 130 bytes of data storage in the Profibus interface. If you intend to use the GSD file then chose from the following options.

INPUT: 128 Byte (64 word) + INPUT: 2 Byte (1 word) = 130 bytes

Or

INPUT: 64 Byte (32 word) + INPUT: 64 Byte (32 word) + INPUT: 2 Byte (1 word) = 130 bytes.

Or

INPUT: 16 Byte (8 word) + INPUT: 16 Byte (8 word) + INPUT: 16 Byte (8 word) + INPUT: 16 Byte (8 word) + INPUT: 2 Byte (1 word) = 130 bytes

```
=====
; Profibus Device Database of HMS Industrial Networks.
; Model : ANYBUS-S PDP
; Description : ANYBUS-S Profibus DP slave
; Language : English
; Date : 12 March 2004
; Author : HMS Industrial Networks AB
;
;=====
#Profibus_DP

; Device identification
Vendor_Name      = "HMS Industrial Networks AB"
Model_Name       = "ANYBUS-S PDP"
Revision         = "Version 1.5"
Ident_Number     = 0x1003
Protocol_Ident   = 0           ; DP protocol
Station_Type     = 0           ; Slave device
FMS_supp        = 0           ; FMS not supported
Hardware_Release = "Version 1.6"
Software_Release = "Version 1.2"

; Supported baudrates
9.6_supp         = 1
19.2_supp        = 1
45.45_supp       = 1
```

93.75_supp = 1
187.5_supp = 1
500_supp = 1
1.5M_supp = 1
3M_supp = 1
6M_supp = 1
12M_supp = 1

; Maximum responder time for supported baud rates

MaxTsdr_9.6 = 15
MaxTsdr_19.2 = 15
MaxTsdr_45.45 = 15
MaxTsdr_93.75 = 15
MaxTsdr_187.5 = 15
MaxTsdr_500 = 15
MaxTsdr_1.5M = 25
MaxTsdr_3M = 50
MaxTsdr_6M = 100
MaxTsdr_12M = 200

; Supported hardware features

Redundancy = 0 ; not supported
Repeater_Ctrl_Sig = 2 ; TTL
24V_Pins = 0 ; not connected
Implementation_Type = "SPC3"

; Supported DP features

Freeze_Mode_supp = 1 ; supported
Sync_Mode_supp = 1 ; supported
Auto_Baud_supp = 1 ; supported
Set_Slave_Add_supp = 0 ; not supported

; Maximum polling frequency

Min_Slave_Intervall = 1 ; 100 us

; Maximum supported sizes

Modular_Station = 1 ; modular
Max_Module = 24
Max_Input_Len = 244
Max_Output_Len = 244
Max_Data_Len = 416
Modul_Offset = 1

Fail_Safe = 0 ; Slave does not accept data frames with zero data length in state CLEAR.

Slave_Family = 0
Max_Diag_Data_Len = 6

```

; Definition of modules
Module = "IN/OUT: 1 Byte" 0x30
EndModule
;
Module = "IN/OUT: 2 Byte ( 1 word)" 0x70
EndModule
;
Module = "IN/OUT: 4 Byte ( 2 word)" 0x71
EndModule
;
Module = "IN/OUT: 8 Byte ( 4 word)" 0x73
EndModule
;
Module = "IN/OUT: 16 Byte ( 8 word)" 0x77
EndModule
;
Module = "IN/OUT: 32 Byte (16 word)" 0x7F
EndModule
;
Module = "IN/OUT: 64 Byte (32 word)" 0xC0,0x5F,0x5F
EndModule
;
Module = "IN/OUT: 128 Byte (64 word)" 0xC0,0x7F,0x7F
EndModule
;
Module = "INPUT: 1 Byte" 0x10
EndModule
;
Module = "INPUT: 2 Byte ( 1 word)" 0x50
EndModule
;
Module = "INPUT: 4 Byte ( 2 word)" 0x51
EndModule
;
Module = "INPUT: 8 Byte ( 4 word)" 0x53
EndModule
;
Module = "INPUT: 16 Byte ( 8 word)" 0x57
EndModule
;
Module = "INPUT: 32 Byte (16 word)" 0x5F
EndModule
;
Module = "INPUT: 64 Byte (32 word)" 0x40,0x5F
EndModule
;
Module = "INPUT: 128 Byte (64 word)" 0x40,0x7F
EndModule

```

```
;
Module = "OUTPUT: 1 Byte" 0x20
EndModule
;
Module = "OUTPUT: 2 Byte ( 1 word)" 0x60
EndModule
;
Module = "OUTPUT: 4 Byte ( 2 word)" 0x61
EndModule
;
Module = "OUTPUT: 8 Byte ( 4 word)" 0x63
EndModule
;
Module = "OUTPUT: 16 Byte ( 8 word)" 0x67
EndModule
;
Module = "OUTPUT: 32 Byte (16 word)" 0x6F
EndModule
;
Module = "OUTPUT: 64 Byte (32 word)" 0x80,0x5F
EndModule
;
Module = "OUTPUT: 128 Byte (64 word)" 0x80,0x7F
EndModule
```