

# ALIGNMENT SENSOR FOR BUCKET ELEVATORS

## ATEX & IECEX APPROVED FOR ZONE 20, 21 & 22 dust

- **Externally mounted non-contact alignment sensor** detecting through a polycarbonate window in the elevator case.
- **Fail Safe.** Magnetic sensor, unaffected by dust or product build up, continuously monitoring the moving target with visual indication by an LED.
- Powerful sensor with 25-50mm sensing range dependant on the size of the target, sensitivity adjustment for optional independent control unit and target detection.
- Equally suited to elevators with steel or plastic buckets (by using bolt heads as targets). Can also suit stainless buckets **please consult our engineers for more information.**
- BAP2 Compatible with our A400 Elite control unit or *Watchdog Elite* and most PLC systems

Detailed specifications, wiring diagrams and installation / operating instructions available immediately upon request.



BAP21V34AI-Cable entry

BAP22V34AI-Conduit entry



**ATEX & IECEX Approved**  
**Ex II 1D T120 C-IP 65-ZONE 20**  
**Ex II 2D T80° C-IP 65-ZONE 21**

*With over 120 years of engineering experience in the bulk handling industry and subsidiaries on all continents along with a worldwide network of distributors, 4B can provide practical solutions for any application no matter the location.*

## SPECIFICATION

Model No	BAP21V34AI	BAP22V34AI
	Cable entry	Conduit entry
Approval	Ex II 1D T120°C & Ex II 2D T80°C	
Supply	12 - 24Vdc	
Supply Current	40 - 90mA	
Outputs, NPN current sinking with pull resistor	100mA (max)	
Protection	IP 65	
Entry	-	Conduit 1/2" NPT
Detection range (dependant on target size)	25 - 50mm	
Cable	6 wire, 2m length	
Weight	405g	428g
Detection rate	20 - 2000/min	
Dimensions	90mm Ø x 35mm	
mounting centres	51 x 51mm	

### CABLE CONNECTIONS

**RED**  
**BLACK**  
**GREEN**  
**YELLOW/ORANGE**  
**BLUE**  
**WHITE**

+ Ve supply 12-24 Vdc (**27VDC MAX.**)  
 - Ve supply 0V  
 Earth (Ground) Connected to case  
 Control 0-24Vdc  
 Pulsed output, normally low - high when detecting  
 Continuous output, normally high - low when detecting

### WATCHDOG ELITE



### MOUNTING

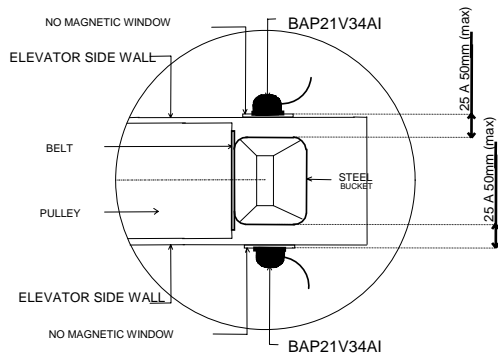

### INTERFACE A400 ELITE



### Connection diagram direct to PLC/computer or to relay

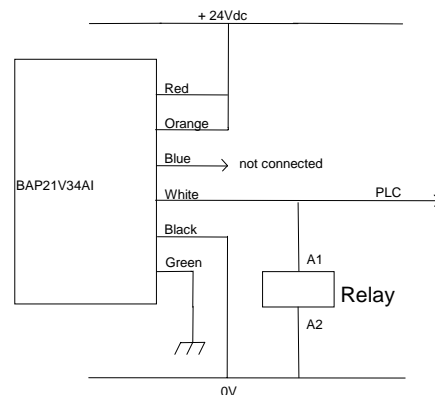

Please refer to instruction manual for correct installation.  
 Information subject to change or correction. July 2011.