

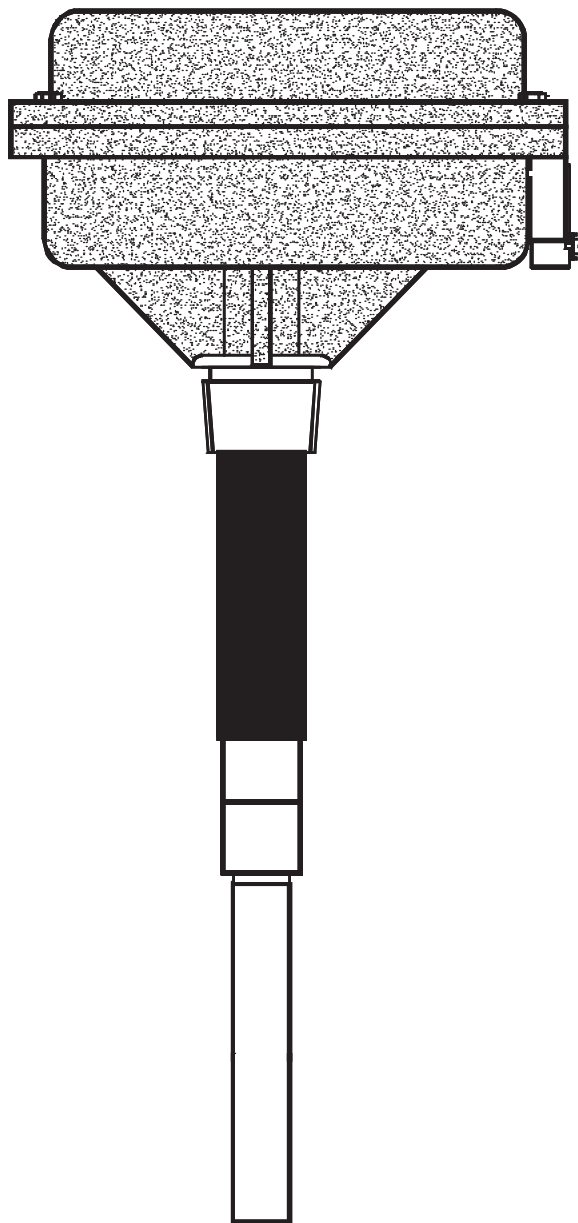

**BRAIME ELEVATOR COMPONENTS LTD. UK**  
**SETEM. FRANCE**



# **AUTOSSET LEVEL CONTROL ATEX APPROVED type ATS6V0A**

Cert. No: BAS01ATEX1403



II1D T100°C

Tamb -20°C to +50°C

**CE**

600

IP65

**INSTALLATION  
INSTRUCTIONS**

## OVERALL SPECIFICATION - ATS6V0A

Type/Certificate No: ..... ATS6VOA M300227A BAS01ATEX1403  
Approval: .....  II1D T100°C Tamb -20°C to +50°C IP65  
Protection: ..... IP65.  
Enclosure: ..... Modified Polyamide 66.  
Mounting: ..... Via 1" BSP Parallel thread.  
Voltage: ..... 110V/230V ac 50/60 Hz or 24V dc  
(+6.5%.to-10%).  
Rating: ..... 2.5VA.  
Operating Temperature: ... -20 to +50°C.  
Output: ..... S.P.C.O contacts rated at 2.5A 240V non-  
inductive.  
Timer Delay: ..... 0 - 128 second variable. (prevents false signal-  
ing from splashing). Set via pushbutton.  
Earth Bonding: ..... Earth stud located on exterior of main case.  
This stud must be connected to earth, bonded  
to container or metalwork of container &, if  
used, connected to exterior of armour cabling.  
Probe Length: ..... 100mm, 1 metre, 2 metre or 10 metre  
wire rope.

---

**To Order:** Specify AUTOSET ATS6V0A + length of probe required

---

### Guarantee

The equipment is covered by a 12 months guarantee from the date of shipment. Any faults arising due to faulty materials or workmanship, within the guarantee period, will be corrected free of charge providing the equipment is returned to us carriage paid.



THIS PRODUCT CONFORMS TO THE REQUIREMENTS FOR CE MARKING

**When this product is incorporated into other machinery or apparatus,  
that apparatus must not then be put into service (in the E.C) until it has  
been declared in conformity with the appropriate E.C Directive/s.**



**BRAIME ELEVATOR  
COMPONENTS LTD.**  
England. LS10 1JZ  
Telephone: (0113)2457491  
Fax: (0113)2435021  
Web: www.braime.com  
e-mail: information@braime.co.uk



**SETEM**  
9, route de Corbie  
80800 LAMOTTE WARFUSEE  
Tél : (33) 03 22 42 32 26  
Fax : (33) 03 22 42 37 33  
Email : setem@aol.com  
www.braime.com/setem

**NOTES:-**

- a) The AUTOSET sensitivity is proportional to the surface area of the probe. When using a 16mm dia. probe the minimum length to use, for the majority of materials, is 200mm. This should be treated as the minimum if possible..

If the probe length needs to be reduced to less than 200mm, the surface area should be maintained. This can be achieved by increasing the diameter, by fitting a metal tube over the probe, or by bending the probe rod. In certain high density materials it may be possible to reduce the length without compensation.

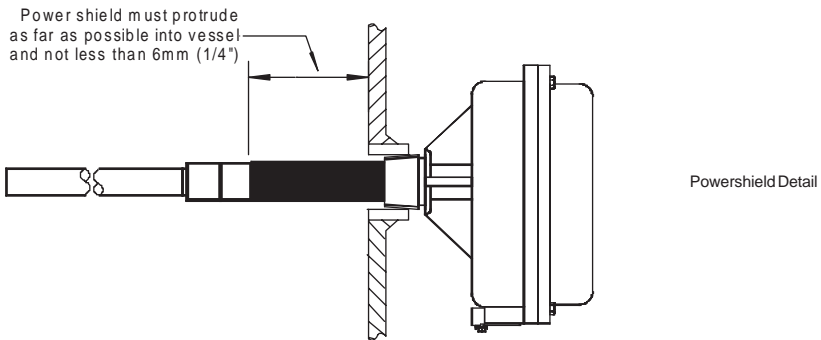
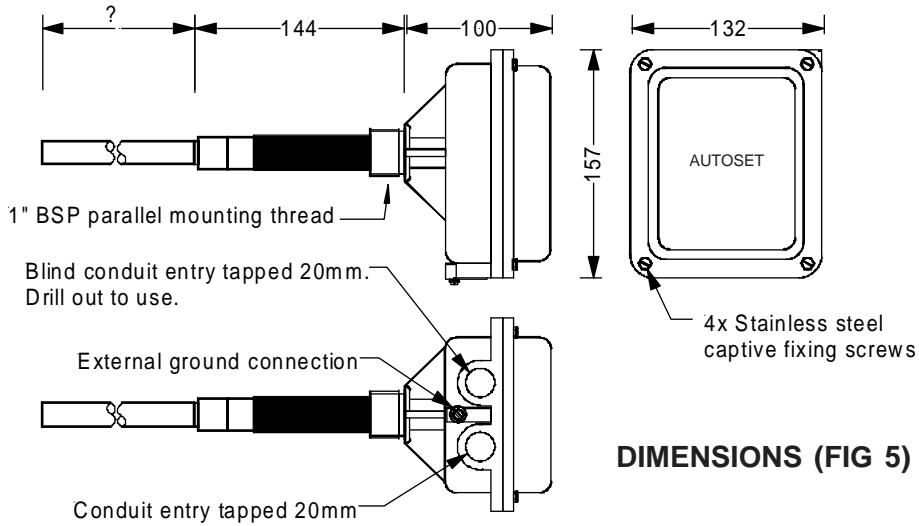

**POWERSHIELD DETAIL (FIG 6)**

## Introduction

The AUTOSET is a fixed point Level Controller incorporating a microcomputer which is used to automatically calibrate the probe to suit the material being detected. Full manual override facilities are included. The unit has full ATEX approval for use in dust hazard installations, such as flour mills, saw mills or any application where dust may be present.

The AUTOSET employs a power shield to minimise the effect of material adhering to the probe making it ideal for detecting most materials including sticky or viscous types. It is equally suited to both liquids and solids. The probe may be a solid rod, metal plate or wire rope.

The self contained AUTOSET is normally supplied with a loose probe, available as a stainless steel rod in standard lengths of 100mm, 1 metre or 2 metres, or as a 10 metre wire rope suspension probe and weight. The probe should be screwed to the AUTOSET. Prior to attachment, the probe length can be reduced or increased, if desired, but see notes a) and b) regarding minimum surface area.

## Connections (fig 1)

### IMPORTANT NOTE:

The AUTOSET is supplied with a fuse fitted in the AC fuseholder, fit into the DC position for 24V dc operation. The fuse rating for this unit is 80mA anti-surge, IEC.

**NO OTHER RATING MAY BE USED**

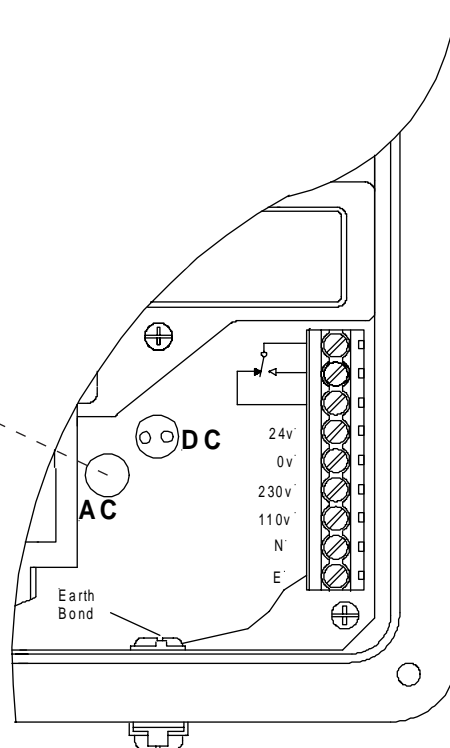

## Installation

A thread locking compound is already applied to the probe fixing stud of the AUTOSET. This will prevent the probe rod from vibrating loose. Once fitted, the compound is fully hardened after 20 minutes.

AUTOSET will operate on 110V/230V ac 50/60Hz or 24V dc supplies. The unit may be wired in ordinary un-screened cable of any length and need not be separated from other cables.

**A SUPPLY EARTH IS ESSENTIAL!**

When mounting the AUTOSET, care must be taken to ensure that the exposed end of the power shield protrudes into the container. See fig. 6. Mount unit securely to minimise vibration.

Connect in accordance with fig 1, and set High/Low switch to required position (see fig 2), ensure that cable gland and back cover are fully tightened when finished. The AUTOSET has two 20mm cable entries, one of which is blank, the blank may be drilled out carefully if required; it must not be knocked out. The unit should be wired and earthed in accordance with appropriate Electrical Regulations. The unit must be earthed and the terminal MUST be bonded to the earth bond stud.

On metal containers, unit earth MUST be bonded to the container. If the container is non-metallic, metal flanges or couplings used to mount probe should be bonded to earth. This also applies to probes mounted in wooden or plastic tops of metal bins.

## Fail Safe Setting

The "High/Low" switch (fig 2), sets the fail safe mode. In the "High" position, the relay is de-energised with material present. In the "Low" position, the relay is energised with material present. Normally, the "High" position is used for high level probes and the "Low" for low level probes. Intermediate probe settings depend upon individual requirements.

FIG 2

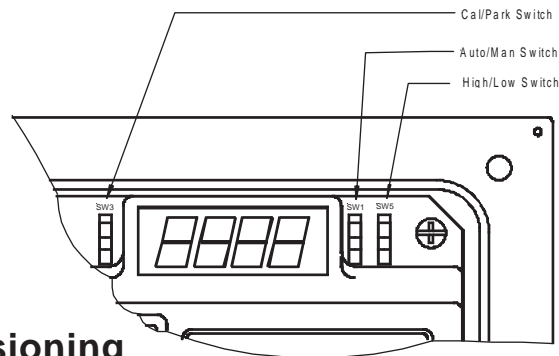

## Commissioning

The AUTOSSET can be calibrated automatically, manually or by a combination of the two methods. Usually, automatic calibration is the simplest method, particularly when the vessel can be filled to cover the probe.

Manual calibration is useful when a number of probes in similar applications need to be set. Once the correct calibration has been determined and noted, on one system, the remainder can be set to the same setting.

### Display Functions

The display shows a number of different values depending upon whether the unit is in manual or auto mode, and cal or park mode.

FIG 3

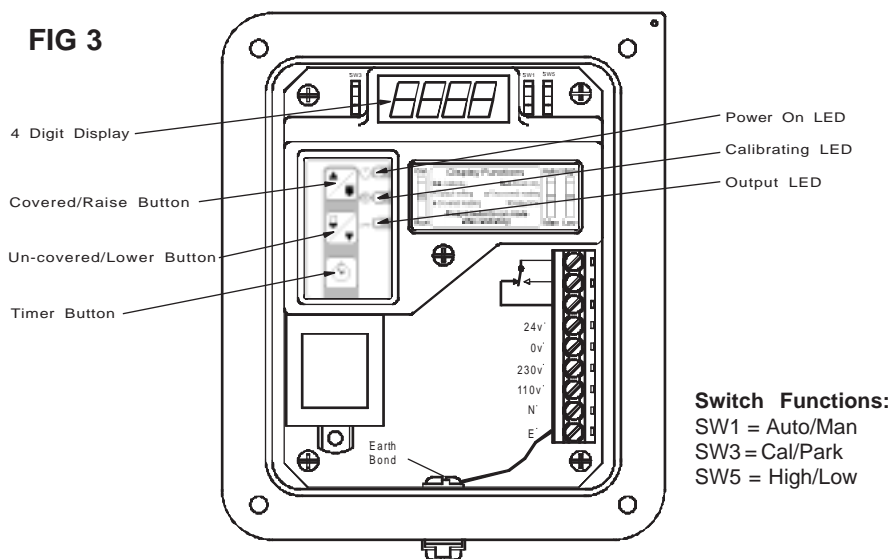

### Park Mode



In normal operation the display shows a value representing the capacitance measured by the probe at the time.

Pressing the  button will cause the display to show uxxx followed by rxxx.



Pressing the  button will cause the display to show cxxx followed by rxxx. cxxx is the probe covered value measured during calibration, uxxx is the uncovered value and rxxx is the relay operating point which the Digimatic calculates and is half way between the two measured values.

**Note:** The settings are "view only" in park mode, they cannot be altered.

### Cal Mode - auto/man switch set to auto

In this mode, pressing the  button will cause the unit to measure and display the uncovered value and recalibrate the relay operating point if necessary. Pressing the  button (with the probe covered) will cause the unit to measure and display the covered value, again recalibrating the relay operating point if necessary.

### **Cal Mode - auto/man switch set to man**





In this mode, pressing the  button will cause the display to momentarily display the present relay operating point and then to increment the setting slowly and then rapidly to set a higher operating point. Pressing the  button will cause the display to momentarily show the current relay operating point, and then decrement the setting, slowly and then rapidly.

Once adjusted in manual mode, any previous settings will be lost. The cxxx reading will be 1 above the relay operating point and the uxxx reading 1 below.





**Note: Always return to "Park" (after calibration)**

---

### **Automatic Calibration - material available**

- 1) Set Park/Cal switch to Cal and Auto/Man switch to Auto. The Cal LED will flash.
- 2) Ensure that the probe is uncovered and press and hold the  button. The display will show uxxx followed by rxxx.
- 3) Fill the vessel sufficiently to cover the probe and then press the  button. Display will show cxxx followed by rxxx.
- 4) Return the Park/Cal switch to park. The unit is now calibrated. uxxx & cxxx values can be viewed but not altered by pressing the  &  buttons.

### **Semi Automatic Calibration - material not available**

- 5) Follow steps 1 & 2 above.
- 6) Set Cal/Park switch to Park and press the  button. Note the uxxx reading but ignore the rxxx reading. Return the Cal/Park switch to Cal and set the Auto/Man switch to Man.
- 7) From the table below, select the nearest material to the type to be detected and add the value to the uxxx reading determined in (6).
- 8) Press the  button to raise the reading and the  button to lower the reading to achieve the calculated setting.
- 9) Return the Cal/Park switch to Park and press the  &  buttons to confirm that the relay operating point rxxx is correctly set. The uxxx & cxxx settings will be one below and one above the readings.



### **Table of Typical Settings**

Material Type	Increment
Light	+15
Medium	+30
Heavy	+60 or greater

---

### **Time Delay**

The AUTOSSET has an adjustable delay from zero to 128 seconds, the timer operating on both material arriving and leaving. To set the time delay, proceed as follows.

- 10) Set the Cal/Park switch to Cal.
- 11) Press and hold the  button. The display will show t000 which increments from zero and adds one second each time the button is pressed. Release the button when the required delay time is shown.
- 12) Return the Cal/Park switch to Park and press  to confirm the timer setting.
- 13) The timer can be altered to a longer or shorter delay by repeating the procedure from 10) above.