

HEAVY DUTY SPEED MONITOR / ENCODER



APPLICATION

The 4B Rotech Encoder is used primarily for protecting equipment and personnel from dangerous underspeed / belt slip conditions.

Other applications include accurate speed control, direction of rotation detection, gate position indication and counting the number of revolutions of the shaft.

It can be used on bucket elevators, conveyors, mixers, fans, pumps, grinders, positioning equipment and all mechanical handling systems.

OPERATION

An inductive sensing device in the body of the encoder detects a steel rotor. On slow speed or accurate position control, a photo diode detects the slots on a steel disk. One pulse is created for each rotor or slot so the unit can be connected directly to a PLC/computer or 4B control module. The shaft to be monitored is drilled and taped to take the M12 Rotech Bolt. No guards are required as the rotating components are encased inside the aluminium housing of the encoder. No brackets are required as the encoder couples directly to the end of the shaft and floats with the shaft.

Polyester and stainless steel versions are also available for offshore and other highly corrosive applications.

OPTION

Mag-con magnetic connector for easy mounting without drilling
Tacho Display
Rotational speed controller AUE 400

Detailed specification, wiring diagrams and installation/operating instructions available immediately upon request.

Please refer to instruction manual for correct installation .
Information subject to change or correction. July 2007.

DIMENSIONS

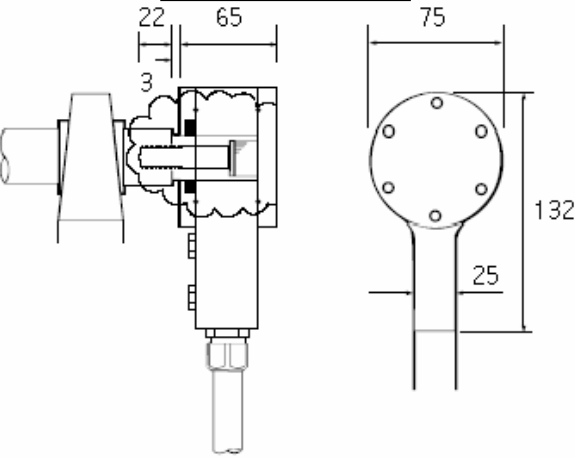

CHARACTERISTICS

Output	NPN , PNP, NAMURE or QUADRATURE
Speed range	0,03 rpm - 1500 rpm (standard) 1500- 5000 rpm (high speed)
Pulse rate	1 to 360
Enclosure	Aluminium or polyester
Weight	1,9 Kg
Protection	IP 65
Temperature	-25°C to +70 °C



ENCODING WHEEL
For direct contact with belt

SHAFT ENCODER

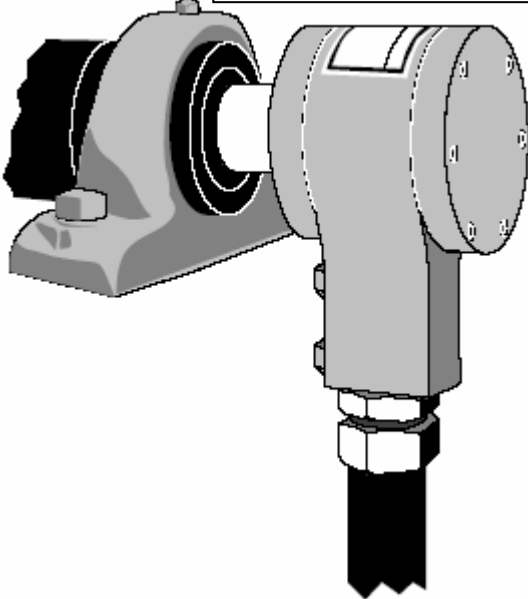

MAG-CON

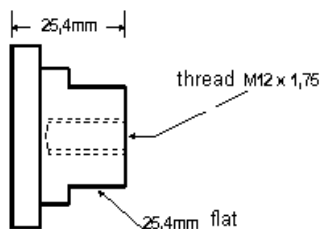
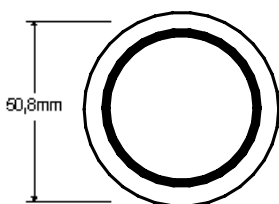

SPEED RELAY AUE 400



Please refer to instruction manual for correct installation .
Information subject to change or correction. July 2007.