

## Bolt 'N' Go

### Flight Installation and Chain Assembly Made Easy!

#### APPLICATION

The Bolt 'N' Go flight system is a revolutionary assembly method for drop forged and round link conveyor chain.

#### METHOD OF OPERATION

**Drop Forged Chain** – Link and flight assembly made easy by using a standard bolt and nut with a high strength hollow pin. There are no circlips to become loose and there is no intricate assembly. There is no welding required on the flights, no need to remove chain from the conveyor for installation, and no issues with strength. Just bolt the links and the flights together. It's easy, simple and reliable!

**Round Link Chain** – Easy flight assembly by using a standard bolt and nut, connecting the flights directly to the link. The chain can be supplied in a coil together with the bolt on flights already assembled.

#### FEATURES

- ▶ Easy and Simple Assembly on Site or in the Shop
- ▶ Precise Calculated Flight Bending Forces
- ▶ No Welding Required
- ▶ Guaranteed and Reliable Pin Attachment
- ▶ Condensed Storage and Shipping Costs
- ▶ Forged Chain and Round Link Chain Compatible
- ▶ Plastic Flight Option (High Density Polyethylene or Nylon)
- ▶ Steel Flight Option (Drop Forged Chain Only)

#### PART NUMBERS/ACCESSORIES

- ▶ See Individual Product Assembly Pages

**FREE**  
Elevator & Conveyor  
Engineering  
Design Service

US Patent # 7,080,728  
Other Patents Pending



Drop Forged Chain Flight Assembly



Round Link Chain Flight Assembly

Detailed specification, wiring diagrams and installation/operating instructions available immediately upon request.

Please refer to instruction manual for correct installation.  
Information subject to change or correction. May 2007.

## Drop Forged Chain Assembly

US Patent # 7,080,728  
Other Patents Pending

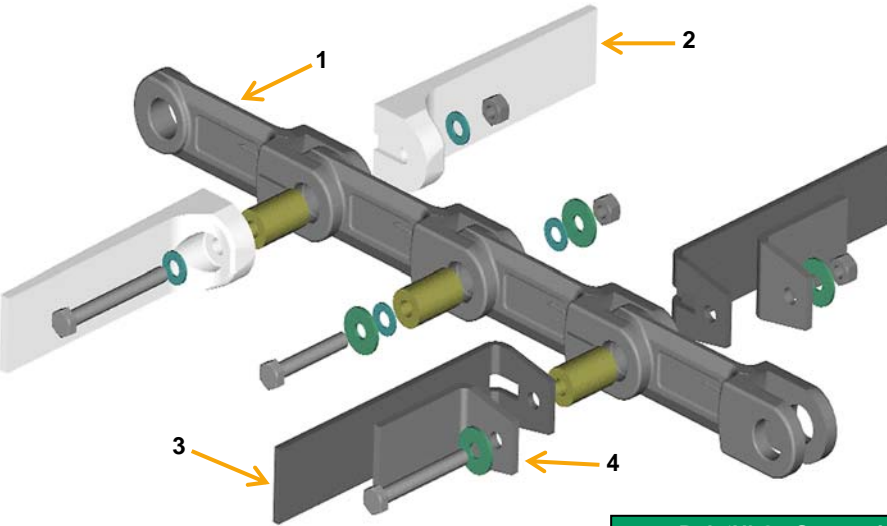

Bolt 'N' Go System Drop Forged Chain Application on a Conveyor

Bolt 'N' Go System is Available on 3 Drop Forged Chain Sizes

#	Description	102 N-A Link	142 N-A Link	142 H-A Link
1	Drop Forged Chain Link	GB0102BNA	GB0142BNA	GB0142BHA
2	Attachable Plastic Flight (Max. Width 16")	GB0142BFP (HDP) GB0142BFN (Nylon)	GB0142BFP (HDP) GB0142BFN (Nylon)	GB0142BFP (HDP) GB0142BFN (Nylon)
3	Attachable Steel Flight (Max. Width 24")	GB0102BF	GB0142BF	GB0142BF
4	Reinforcement Plate (For Flights Over 16")	Not Required	GB0142BBF	GB0142BBF
5	Bolt 'N' Go Assembly Kits (Pins Included)	GB0102NPAC - No Flights GB0102NPAF - Flights	GB0142NPAC - No Flights GB0142NPAF - Flights	GB0142HPAC - No Flights GB0142HPAF - Flights

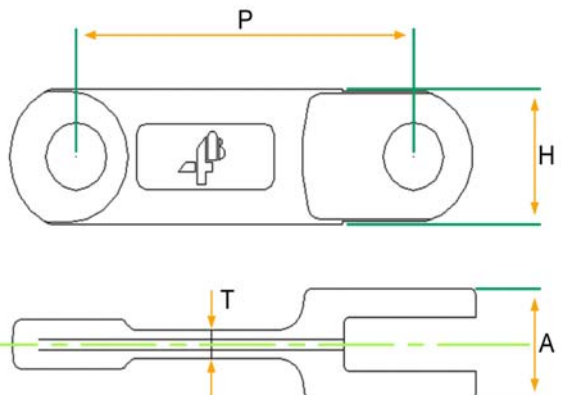
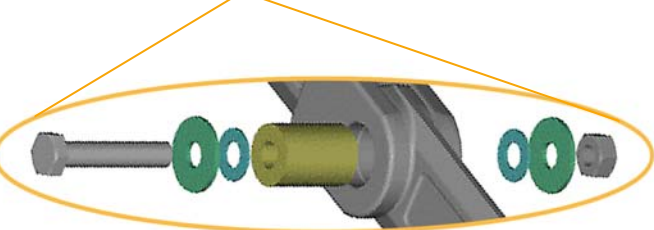

### TECHNICAL SPECIFICATIONS

#### Bolt 'N' Go – Drop Forged Chain Link

Link	P	H	A	T	Weight	Minimum Breaking Load	Case Hardness	Case Depth	Core Hardness
102 N-A	102 mm 4.02 in	36 mm 1.42 in	28 mm 1.10 in	7.62 mm .30 in	.35 kg .80 Lbs	150 KN 33,000 Lbs	Rockwell C 59/64	.5 mm .02 in	Rockwell C40
142 N-A	142 mm 5.59 in	50 mm 1.97 in	42 mm 1.65 in	11 mm .43 in	1.26 kg 2.80 Lbs	300 KN 67,200 Lbs	Rockwell C 59/64	.7 mm .03 in	Rockwell C40
142 H-A	142 mm 5.59 in	50 mm 1.97 in	62 mm 2.44 in	16.5 mm .65 in	2.00 kg 4.40 Lbs	450 KN 100,800 Lbs	Rockwell C 59/64	.7 mm .03 in	Rockwell C40

Please refer to instruction manual for correct installation.  
Information subject to change or correction. May 2007.

## Round Link Chain Assembly

US Patent # 7,080,728  
Other Patents Pending

#	Description	Part Number
1	Attachable Plastic Flight	GB1365BPF
2	M10 x 45 Bolt	GB142BM1045HEX
3	Washer (Not Shown)	GB142BM10W
4	Nylock Nut	GB142BM1045NYL
5	Round Link Chain	GB1235BRL
6	Link Connector (Not Shown)	GB1365BC

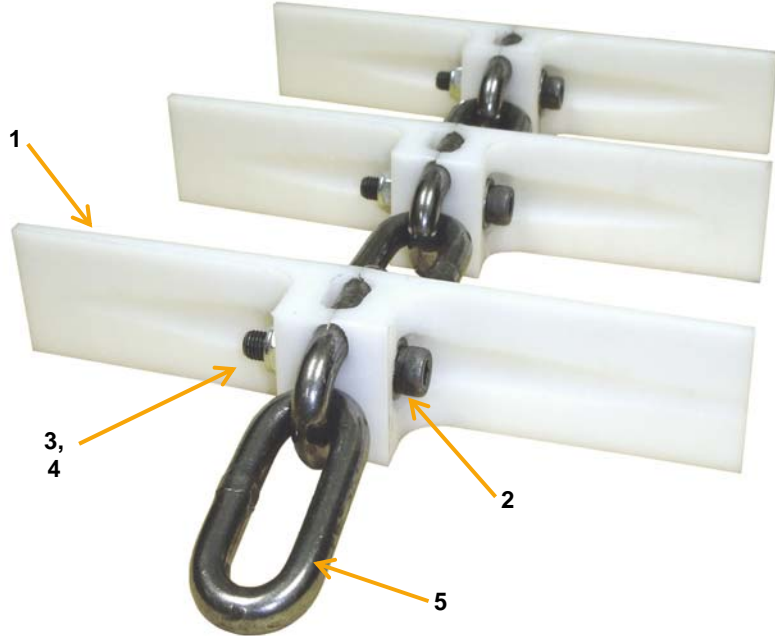

### TECHNICAL SPECIFICATIONS

Bolt 'N' Go – Drop Forged Chain Link

#### Absorbed Power (kW)

		Conveyor Length - Meters										
		15	20	25	30	35	40	45	50	60	70	80
Capacity t/h	50	1.7	2.2	2.8	3.4	3.9	4.5	5.0	5.6	6.7	7.9	9.0
	75	2.2	2.9	3.7	4.4	5.1	5.8	6.6	7.3	8.8	10.2	11.7
	100	3.1	4.1	5.1	6.1	7.2	8.2	9.2	10.2	12.3	14.3	16.4
	150	4.4	5.9	7.4	8.9	10.4	11.8	13.3	14.8	17.8	20.7	23.7
	200	5.8	7.8	9.7	11.7	13.6	15.6	17.5	19.5	23.4	27.3	31.2

#### Chain Pull (kN)

		Conveyor Length - Meters										
		15	20	25	30	35	40	45	50	60	70	80
Capacity t/h	50	2.8	3.7	4.7	5.6	6.5	7.5	8.4	9.3	11.2	13.1	15.0
	75	3.7	4.9	6.1	7.3	8.5	9.7	11.0	12.2	14.6	17.1	19.5
	100	4.4	5.8	7.3	8.8	10.2	11.7	13.2	14.6	17.5	20.5	23.4
	150	5.9	7.9	9.9	11.8	13.8	15.8	17.8	19.7	23.7	27.6	31.6
	200	7.3	9.7	12.2	14.6	17.1	19.5	21.9	24.4	29.2	34.1	39.0

#### Minimum Chain UTS (kN) - 5:1 Safety Factor

		Conveyor Length - Meters										
		15	20	25	30	35	40	45	50	60	70	80
Capacity t/h	50	14.0	18.7	23.4	28.0	32.7	37.4	42.1	46.7	56.1	65.4	-
	75	18.3	24.4	30.4	36.5	42.6	48.7	54.8	60.9	73.1	-	-
	100	21.9	29.2	36.5	43.9	51.2	58.5	65.8	73.1	-	-	-
	150	28.3	37.8	47.2	56.6	66.1	-	-	-	-	-	-
	200	33.7	44.9	56.2	67.4	-	-	-	-	-	-	-
	250	39.4	52.5	65.6	-	-	-	-	-	-	-	-
	300	45.0	60.0	-	-	-	-	-	-	-	-	-

Link Material: Case Hardened Steel

Flight Material: High Density Polyethylene

Bolt Material: Carbon Steel



Bolt 'N' Go System Drop Forged Chain Application on a Conveyor

Please refer to instruction manual for correct installation. Information subject to change or correction. May 2007.