

High intensity - Rare Earth



Preface:

The Eclipse high intensity housed drum magnet is ideal for the continuous removal of tramp ferrous contamination from any dry bulk material. Often installed in the most arduous of applications

These units can be relied upon to ensure contamination extraction is achieved.

Housed drums should be fitted at the discharge end of conveyors, vibratory feeders or inline chute sections. High performance Rare Earth magnets are incorporated within a stainless steel wear resistant drum shell. The magnets remain static as the drum rotates enabling the unit to continually clean.

Units are available for all product volume flows ranging from 5-500m³/hr and a contamination loading of up to 50% of the total product volume.

Cleaning:

Contamination entering the housing is fed onto the drum surface where it is attracted. As the drum rotates, carry over fins move the contamination to the rear of the drum where the magnetic area ends, enabling the contamination to fall through the reject

chute section of the housing. The drum rotates at between 20-25 RPM ensuring that even the most heavily contaminated product can be separated.

Suitable Products:

Dry powders, granulates, grain and sand etc.

Suitable Locations:

End of conveyor belt, vibratory feeder or inline chute sections.

Benefits:

Continuous self cleaning ■ Allows difficult products to be screened ■ High volume capacity ■ Reduces 'spark' risk ■ Removes large to medium sized contamination ■

Category:

Primary.



Technical Data:

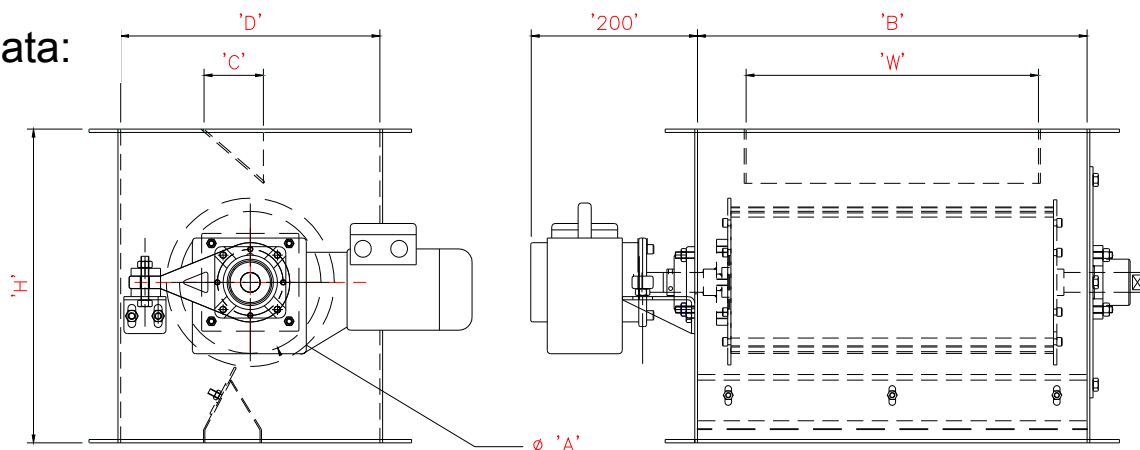

Sizes:-

Part No	Dia A	Width B	Depth D	Inlet Length W	Inlet Width C	Height H	Weight Kgs
HDMN2140	215 / 8.5"	500	400	350	75	475	125
HDMN2150	215 / 8.5"	600	400	450	75	475	135
HDMN2160	215 / 8.5"	700	400	550	75	475	150
HDMN2170	215 / 8.5"	800	400	650	75	475	165
HDMN2180	215 / 8.5"	900	400	750	75	475	185
HDMN2190	215 / 8.5"	1000	400	850	75	475	210
HDMN21100	215 / 8.5"	1100	400	950	75	475	235
HDMN3140	315 / 12.5"	500	500	350	125	650	150
HDMN3150	315 / 12.5"	600	500	450	125	650	160
HDMN3160	315 / 12.5"	700	500	550	125	650	175
HDMN3170	315 / 12.5"	800	500	650	125	650	200
HDMN3180	315 / 12.5"	900	500	750	125	650	220
HDMN3190	315 / 12.5"	1000	500	850	125	650	245
HDMN31100	315 / 12.5"	1100	500	950	125	650	275
HDMN4040	400 / 15.75"	500	585	350	175	750	185
HDMN4050	400 / 15.75"	600	585	450	175	750	205
HDMN4060	400 / 15.75"	700	585	550	175	750	220
HDMN4070	400 / 15.75"	800	585	650	175	750	240
HDMN4080	400 / 15.75"	900	585	750	175	750	265
HDMN4090	400 / 15.75"	1000	585	850	175	750	290
HDMN40100	400 / 15.75"	1100	585	950	175	750	315

Performance:-

Magnetic Performance:

Rare Earth 3,500 Gauss

Magnetic Material:

Rare Earth Neodymium Iron Boron

Magnetic Field Depth:

215mm Dia = 85mm – 315mm Dia = 100mm – 400mm Dia 150mm*

Temperature:

-20° C / + 80° C

*Mild Steel test piece 5mm Ø x 25mm long

All dimensions in mm

Materials:-

Housing:

304 Grade Stainless Steel

Drum Shell:

304 Grade Stainless Steel – Aerospace Quality

Electrical Spec:

415/380 Volts industrial three phase IP54 rated motor gearbox

Surface Finish:

Bead blasted

Sealing:

Self adhered white foam

Options:-

High temperature Samarium Cobalt magnetic material + 250° C

316 Grade Stainless Steel

ATEX certified

