

## High intensity - Rare Earth

### Preface:

The Eclipse high intensity magnetic Chute separator has been designed to operate in arduous conditions and where contamination size is relatively large e.g. nuts, bolts etc.

The unit comprises of two hinged, high intensity magnetic packs, which are secured to a housing via an adjustable hinge arrangement and tricone locking nut. It is these tricone nuts that ensure even pressure is generated around the food grade silicon seal.

The Chute magnet can be incorporated into any form of vertical or angled pipe or chute section. A common installation location is raw material inlet points such as grain, rice, corn, bran and animal feed etc. A central diverter is mounted on the inlet, which ensures that the processed product is directed onto the magnetic face ensuring a high contamination removal rate.

All powders and granular type materials that are dry can be processed through the unit. Electrical safety interlocks can be fitted to the magnetic packs to stop the process should they be accidentally opened.



### Cleaning:

The Eclipse Chute magnet benefits from the Eclipse 'Easy Clean' system fig A.

Once the unit requires cleaning simply release the quick release Toggle clamps, swing the packs away from the line & hinge the easy clean plates away. The collected contamination will be free from magnetic attraction and can be simply and easily removed allowing for inspection or further analysis.

### Suitable Products:

Dry powders and granulates.

### Suitable Locations:

Inlet/outlet points.

### Benefits:

Easy to clean ■ Maintains full flow ■ High collection capacity ■  
Reduces 'spark' risk ■ Removes 'tramp' sized contaminants ■  
Meet audit requirements ■ Rare Earth deep magnetic field ■

### Category:

Primary.



Fig A.



# Chute Magnet

TECHNOLOGY · INNOVATION · QUALITY · VALUE

## Technical Data:

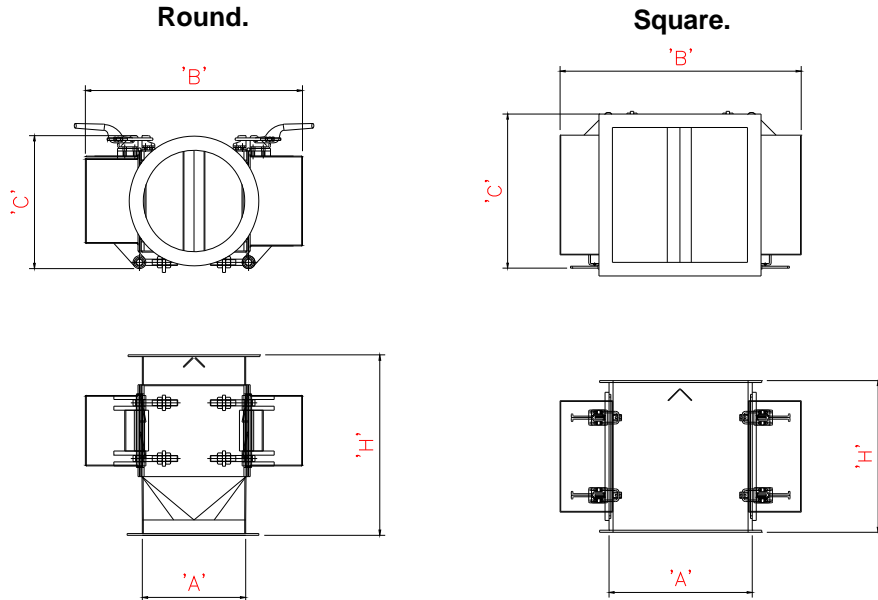

### Sizes:-

Part No	Inlet/Outlet A (mm / " )	Width B	Depth C	Height H	Weight Kgs
<b>Round</b>					
CMN150	150 / 6" Ø	350	250	270	24
CMN200	200 / 8" Ø	400	300	300	32
CNM250	250 / 10" Ø	450	350	400	42
CMN300	300 / 12" Ø	500	400	450	56
<b>Square</b>					
CMN1515	150 / 6" Sq	330	220	200	22
CMN2020	200 / 8" Sq	380	270	250	30
CMN2525	250 / 10" Sq	450	320	300	39
CMN3030	300 / 12" Sq	500	370	350	52

### Performance:-

<b>Magnetic Performance:</b>	3,500 Gauss	All dimensions in mm
<b>Performance Reading:</b>	On magnetic pack surface	
<b>Magnetic Material:</b>	Rare Earth Neodymium Iron Boron	
<b>Magnet Grade:</b>	N35 – Inspected & confirmed via hystergaph prior to use	
<b>Temperature:</b>	-20° C / + 60° C	
<b>Pressure:</b>	+/- 0.2 Bar	

### Materials:-

<b>Housing:</b>	316 Grade Stainless Steel
<b>Other Parts:</b>	316 Grade Stainless Steel
<b>Surface Finish:</b>	Brushed internally/externally to 1.2µm
<b>Sealing:</b>	Self adhered white foam
<b>Toggle Clamps:</b>	Mild Steel – Bright Zinc plated

### Options:-

Stainless Steel toggle clamps	High temperature Samarium Cobalt magnetic material, + 250° C
Overpressure to +/- 5 Bar	Sizes up to 500mm Ø or square
304 Grade Stainless Steel	Pharmaceutical specification
ATEX certified	Flanged to suit
Safety relay switches	Metal detectable Silicon rubber seal – Dark blue, FDA Approved
Ceramic magnetic material	

