

High intensity - Rare Earth



Preface:

The Eclipse Auto-Rota Shuttle has the benefits of the Eclipse Auto-Shuttle and Rota-Grid unit in one. The Auto-Rota Shuttle enables screening of difficult bridging and or caking products to be processed 24hrs a day seven days a week without the need for manual intervention. The system can even carry out a full clean without the need to stop the process enabling continuous production.

The unit is supplied with a pre programmed PLC that can either work independently or connected to the central control rooms system for remote activation or monitoring etc.

The full system remains air tight throughout normal operation making it suitable for environments where ATEX equipment is required.

Cleaning:

The magnetic cores remain in the process chamber, when a cleaning signal is given compressed air is fed into each separator tube forcing the core to the other end of the unit. The contamination follows the core, which first passes through the product return chamber, which prevents loss of good product and into the cleaning chamber where the collected contamination is deposited.

The cleaning chamber is fitted with a transition piece, which allows a collection container to be fitted. It is this container that is removed to assess the collected contamination.

Suitable Products:

Dry & semi-dry powders and granulates, starch, protein etc.

Suitable Locations:

Any vertical process line.

Benefits:

Fully autonomous in operation ■ Reduces 'spark' risk ■ Suitable for control room connection ■ Removes sub micron sized contaminants ■ Meet audit requirements ■ Rare Earth 9,000 Gauss ■ Allows difficult products to be screened ■

Category:

Secondary.

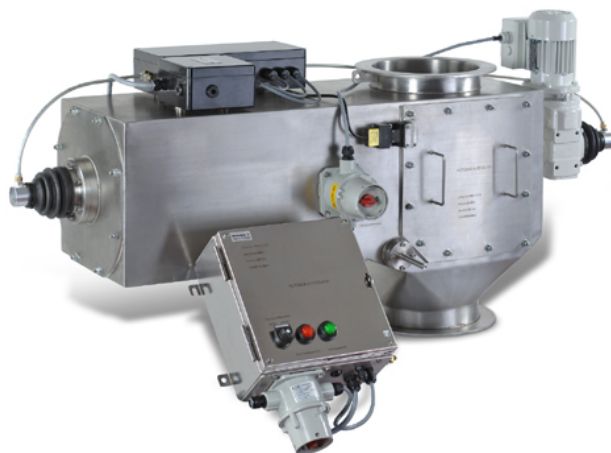

Reject chamber outlet Product outlet



Technical Data:

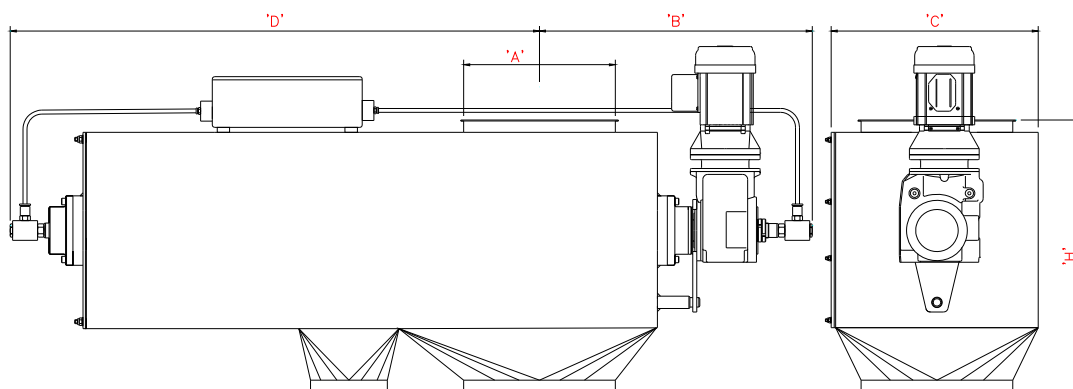

Sizes:-

Part No	Inlet/Outlet	A	B	C	D	Height H	KW Rating	No Rods	Weight
Round									
ASRG150	150mm / 6" Ø		475	815	250	400	0.18	5	90
ASRG200	200mm / 8" Ø		500	915	300	450	0.18	6	105
ASRG250	250mm / 10" Ø		525	1015	350	500	0.18	7	120
ASRG300	300mm / 12" Ø		550	1115	400	550	0.18	9	135
ASRG350	350mm / 14" Ø		575	1215	450	600	0.25	10	150
ASRG400	400mm / 16" Ø		600	1315	500	650	0.25	13	165
ASRG450	450mm / 18" Ø		625	1415	550	700	0.25	15	180
Square									
ASRG1515	150mm / 6" Sq		475	815	250	400	0.18	5	88
ASRG2020	200mm / 8" Sq		500	915	300	450	0.18	6	100
ASRG2525	250mm / 10" Sq		525	1015	350	500	0.18	7	112
ASRG3030	300mm / 12" Sq		550	1115	400	550	0.18	9	126
ASRG3535	350mm / 14" Sq		575	1215	450	600	0.25	10	142
ASRG4040	400mm / 16" Sq		600	1315	500	650	0.25	13	155
ASRG4545	450mm / 18" Sq		625	1415	550	700	0.25	15	168

Performance:-

Magnetic Performance:	9,000 Gauss - High Strength
Performance Reading:	On tube surface
Magnetic Material:	Rare Earth Neodymium Iron Boron
Magnet Grade:	N45 – Inspected & confirmed via hystergaph prior to use
Temperature:	-20° C/ + 60° C

All dimensions in mm

Materials:-

Housing:	316 Grade Stainless Steel
Tubing:	316 Grade Stainless Steel – Aerospace Quality
Other Parts:	316 Grade Stainless Steel
Surface Finish:	Brushed internally/externally to 1.2µm
Sealing:	Self adhered white foam
Tricone Nuts:	Stainless Steel & Moulded Plastic

Options:-

High temperature Samarium Cobalt magnetic material + 250° C
Siemens, Mitsubishi or Allen Bradley PLC
304 Grade Stainless Steel
Metal detectable Silicon rubber seal – Dark blue, FDA Approved

Flanged to suit
Pharmaceutical specification
ATEX certified

