

High intensity - Rare Earth



Preface:

The Eclipse Auto-Shuttle magnetic separator enables screening of processed products 24hrs a day seven days a week without the need for manual intervention. The system can even carry out a full clean without the need to stop the process enabling continuous production.

The unit is supplied with a pre programmed PLC that can either work independently or connected to the central control rooms system for remote activation or monitoring etc.

There are reed switches fitted to each end of the separator tubes to indicate the position of each magnetic core. The full system remains air tight throughout normal operation making it suitable for environments where ATEX equipment is required.

Cleaning:

The magnetic cores remain in the process chamber, when a cleaning signal is given compressed air is fed into each separator tube forcing the core to the other end of the unit. The contamination follows the core, which first passes the rough the product return chamber, which prevents loss of good product and into the cleaning chamber where the collected contamination is deposited.

The cleaning chamber is fitted with a transition piece, which allows a collection container to be fitted. It is this container that is removed to assess the collected contamination.

Suitable Products:

Dry powders and granulates, flour, sugar, herbs & salt, etc

Suitable Locations:

Any vertical process line.

Benefits:

Fully autonomous in operation ■ Reduces 'spark' risk ■ Suitable for control room connection ■ Removes micron sized contaminants ■ Meet audit requirements ■ Rare Earth 9,000 Gauss ■

Category:

Secondary



Technical Data:

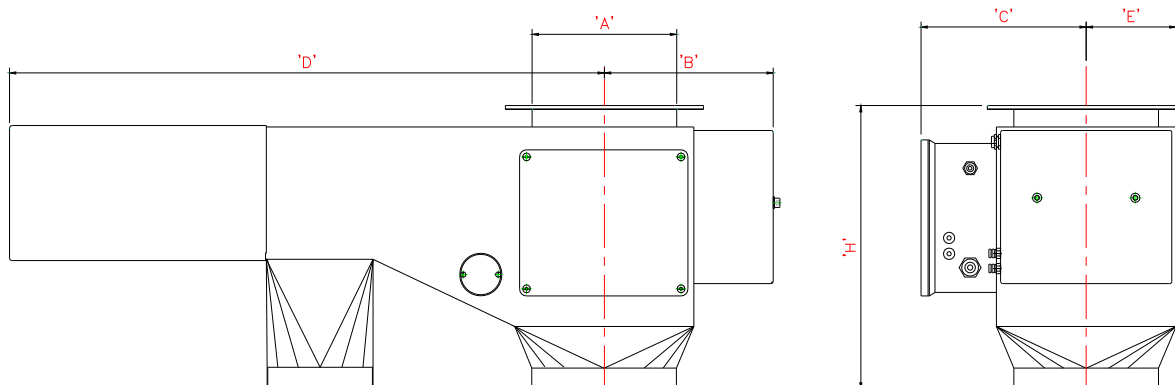

Sizes:-

Part No	Inlet/Outlet	A	B	D	C	E	Height H	No Rods	Weight Kgs
Round									
ASHD150	150mm / 6" Ø		217	775	215	103	400	3 + 2	31
ASHD200	200mm / 8" Ø		242	850	240	128	400	3 + 2	38
ASHD250	250mm / 10" Ø		267	925	265	153	400	4 + 3	47
ASHD300	300mm / 12" Ø		292	1000	290	178	400	5 + 4	58
ASHD350	350mm / 14" Ø		317	1075	315	203	400	6 + 5	69
ASHD400	400mm / 16" Ø		342	1150	340	228	400	7 + 6	81
ASHD450	450mm / 18" Ø		367	1225	365	253	400	8 + 7	96
Square									
ASHD1515	150mm / 6" Sq		192	725	190	78	350	2 + 2	24
ASHD2020	200mm / 8" Sq		217	800	215	103	350	3 + 2	28
ASHD2525	250mm / 10" Sq		242	875	240	128	350	3 + 2	35
ASHD3030	300mm / 12" Sq		267	950	265	153	350	4 + 3	43
ASHD3535	350mm / 14" Sq		292	1025	290	178	350	5 + 4	52
ASHD4040	400mm / 16" Sq		317	1100	315	203	350	6 + 5	61
ASHD4545	450mm / 18" Sq		342	1175	340	228	350	7 + 6	74

Performance:-

Magnetic Performance:	9,000 Gauss - High Strength	All dimensions in mm
Performance Reading:	On tube surface	
Magnetic Material:	Rare Earth Neodymium Iron Boron	
Magnet Grade:	N45 – Inspected & confirmed via hystergraph prior to use	
Temperature:	-20° C/ + 90° C	
Pressure:	+/- 0.2 Bar	

Materials:-

Housing:	316 Grade Stainless Steel
Tubing:	316 Grade Stainless Steel – Aerospace Quality
Other Parts:	316 Grade Stainless Steel
Surface Finish:	Brushed internally/externally to 1.2µm
Sealing:	Self adhered white foam
PLC:	Crouzet, pre-programmed

Options:-

High temperature Samarium Cobalt magnetic material + 250° C	
Overpressure to + 5 Bar	Siemens, Mitsubishi or Allen Bradley PLC
304 Grade Stainless Steel	Pharmaceutical specification
ATEX certified	Metal detectable Silicon rubber seal – Dark blue, FDA Approved
Flanged to suit	Single, Triple & Quad row units available

